

Digital Signage

User's Manual





Foreword

General

This manual introduces the functions and operations of the Digital Signage (hereinafter referred to as the "Signage"). Read carefully before using the Signage, and keep the manual safe for future reference.

Safety Instructions

Signal Words	Meaning
 WARNING	Indicates a medium or low potential hazard which, if not avoided, could result in slight or moderate injury.
 CAUTION	Indicates a potential risk which, if not avoided, could result in property damage, data loss, reductions in performance, or unpredictable result.
 NOTE	Provides additional information as a supplement to the text.

Revision History

Version	Revision Content	Release Time
V1.0.2	Updated 43-inch and 55-inch dimension figures.	April 2024
V1.0.1	Updated some dimension and installation figures.	March 2024
V1.0.0	First release.	March 2024

Privacy Protection Notice

As the device user or data controller, you might collect the personal data of others such as their face, audio, fingerprints, and license plate number. You need to be in compliance with your local privacy protection laws and regulations to protect the legitimate rights and interests of other people by implementing measures which include but are not limited to: Providing clear and visible identification to inform people of the existence of the surveillance area and provide required contact information.

About the Manual

- The manual is for reference only. Slight differences might be found between the manual and the product.
- We are not liable for losses incurred due to operating the product in ways that are not in compliance with the manual.
- The manual will be updated according to the latest laws and regulations of related jurisdictions. For detailed information, see the paper user's manual, use our CD-ROM, scan the QR code or visit our official website. The manual is for reference only. Slight differences might be found between the electronic version and the paper version.

- All designs and software are subject to change without prior written notice. Product updates might result in some differences appearing between the actual product and the manual. Please contact customer service for the latest program and supplementary documentation.
- There might be errors in the print or deviations in the description of the functions, operations and technical data. If there is any doubt or dispute, we reserve the right of final explanation.
- Upgrade the reader software or try other mainstream reader software if the manual (in PDF format) cannot be opened.
- All trademarks, registered trademarks and company names in the manual are properties of their respective owners.
- Please visit our website, contact the supplier or customer service if any problems occur while using the device.
- If there is any uncertainty or controversy, we reserve the right of final explanation.

Important Safeguards and Warnings

This section introduces content covering the proper handling of the device, hazard prevention, and prevention of property damage. Read carefully before using the device, and comply with the guidelines when using it.

Transportation Requirements



Transport the device under allowed humidity and temperature conditions.

Storage Requirements



Store the device under allowed humidity and temperature conditions.

Installation Requirements



Stability Hazard

Possible result: The device might fall down and cause serious personal injury.

Preventive measures (including but not limited to):

- Only use cabinets and brackets specified for the device.
- Only use furniture and structures that can safely support the device.
- Do not place the device on the edge of the furniture or structure that is supporting it.
- Always educate children about the dangers of climbing furniture to reach the device and its controller.
- Carefully arrange the cables connected to the device to avoid people tripping over them and pulling on them.
- Make sure that the device is installed on a stable surface.
- Do not put the device on tall furniture, such as cabinets and bookcases, without first ensuring that the supporting structure is stable enough to bare the device.
- Do not place the device on fabric and other similar material.
- Do not place items, such as toys and remote controls, that may entice children to climb on top of the device or furniture on which the device is placed.



- Do not connect the power adapter to the device while the adapter is powered on.
- Strictly comply with the local electrical safety code and standards. Make sure that the ambient voltage is stable and meets the power supply requirements of the device.
- Do not connect the device to two or more kinds of power supplies, to avoid safety risks and damage to the device.
- Please follow the electrical requirements to power the device.

- ◇ Following are the requirements for selecting a power adapter.
 - The power supply must conform to the requirements of IEC 60950-1 and IEC 62368-1 standards.
 - The voltage must meet the SELV (Safety Extra Low Voltage) requirements and not exceed ES-1 standards.
 - When the power of the device does not exceed 100 W, the power supply must meet LPS requirements and be no higher than PS2.
- ◇ We recommend using the power adapter provided with the device.
- ◇ When selecting the power adapter, the power supply requirements (such as rated voltage) are subject to the device label.
- Use the standard power adapter. We will assume no responsibility for any problems caused by the use of a nonstandard power adapter.
- Use the power cords that are recommended for the region and conform to the rated power specifications.



- Do not place the device in a place exposed to sunlight or near heat sources.
- Keep the device away from dampness, dust, and soot.
- Install the device in a well-ventilated place, and do not block its ventilation.
- The device is a class I electrical appliance. Make sure that the power supply of the device is connected to a power socket with protective earthing.
- When installing the device, make sure that the power plug can be easily reached to cut off the power.

Operation Requirements



-  The device or remote control contains button batteries. Do not swallow the batteries due to the risk of chemical burns.
Possible result: The swallowed button battery can cause serious internal burns and death within 2 hours.
Preventive measures (including but not limited to):
 - ◇ Keep new and used batteries out of reach of children.
 - ◇ If the battery compartment is not securely closed, stop using the product immediately and keep out of reach of children.
 - ◇ Seek immediate medical attention if a battery is believed to be swallowed or inserted inside any part of the body.
- Battery Pack Precautions
Preventive measures (including but not limited to):
 - ◇ Do not transport, store or use the batteries in high altitudes with low pressure and environments with extremely high and low temperatures.
 - ◇ Do not dispose the batteries in fire or a hot oven, or mechanically crush or cut the batteries to avoid an explosion.
 - ◇ Do not leave the batteries in environments with extremely high temperatures to avoid explosions and leakage of flammable liquid or gas.
 - ◇ Do not leave the batteries in environments with extremely high temperatures to avoid explosions and leakage of flammable liquid or gas.



WARNING

- In a domestic environment this may cause radio interference in which case you may be required to take adequate measures.
- Ground the device to protective ground before you power it on.



- Use the device under allowed humidity (10%–85% (RH)) and temperature (0 °C to 40 °C, or 32 °F to 104 °F).
- Check whether the power supply is correct before use.
- Operate the device within the rated range of power input and output.
- Do not drop or splash liquid onto the device, and make sure that there is no object filled with liquid on the device to prevent liquid from flowing into it.
- Do not disassemble the device without professional instruction.

Maintenance Requirements



DANGER

Replacing unwanted batteries with the wrong type of new batteries might result in explosion.

Preventive measures (including but not limited to):

- Replace unwanted batteries with new batteries of the same type and model to avoid the risk of fire and explosion.
- Dispose of the old batteries as instructed.



The appliance coupler is a disconnection device. Keep it at a convenient angle when using it.

Table of Contents

Foreword.....	I
Important Safeguards and Warnings.....	III
1 Overview.....	1
2 Structure.....	2
2.1 Dimensions.....	2
2.1.1 Dimensions (43-inch).....	2
2.1.2 Dimensions (50-inch).....	3
2.1.3 Dimensions (55-inch).....	4
2.1.4 Dimensions (65-inch).....	5
2.2 Ports.....	5
3 Installation.....	7
3.1 Installing the Signage.....	7
3.2 (Optional) Installing the Antenna.....	9
4 Basic Operations.....	10
4.1 Starting and Shutting Down.....	10
4.2 Initializing the Signage.....	10
4.3 Login.....	13
4.4 Changing Password and Security Questions.....	14
4.4.1 Setting Password Validity Period.....	14
4.4.2 Changing Password.....	15
4.4.3 Changing Security Questions.....	16
4.4.4 Resetting Password.....	17
4.5 Quick Toolbar.....	17
4.6 Project Release.....	18
4.6.1 Network Release.....	18
4.6.2 Local Release.....	23
4.7 App Manager.....	35
4.7.1 Installing App.....	35
4.7.2 File Manager.....	36
5 System Settings.....	37
5.1 Setting Date & Time.....	37
5.2 Selecting Input Source.....	37
5.3 Configuring Visual & Audio Parameters.....	38
5.4 System Language.....	39
6 Maintenance and Update.....	40
6.1 Maintenance Requirements.....	40
6.2 Restoring Factory Defaults.....	40

6.3 Upgrading System.....	40
6.4 Configuring Auto Maintenance Time.....	41
6.5 Configuring Timed Screen On/off.....	41
6.6 Configuring Timed Power On/off.....	42
6.7 Enabling HDMI Standby.....	43
6.8 Restarting Device.....	43
6.9 Viewing Device Information.....	43
Appendix 1 Remote Control.....	44
Appendix 2 Security Recommendation.....	46

1 Overview

The Signage is an innovative, intelligent cloud information terminal that features multimedia content release, advertisement and network access. The Signage is applicable for use in government buildings, office parks, shopping malls, and more.

2 Structure

2.1 Dimensions

2.1.1 Dimensions (43-inch)

Figure 2-1 Dimensions (43-inch) (mm [inch])

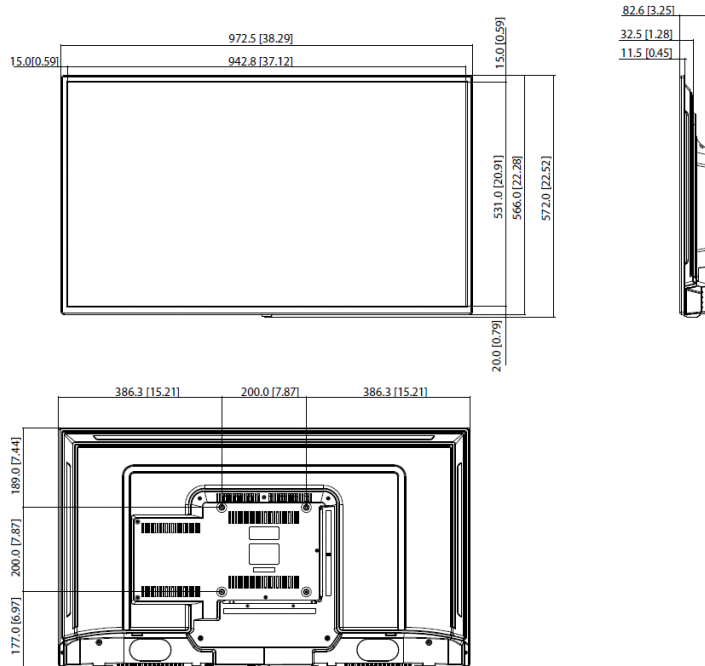

2.1.2 Dimensions (50-inch)

Figure 2-2 Dimensions (50-inch) (mm [inch])

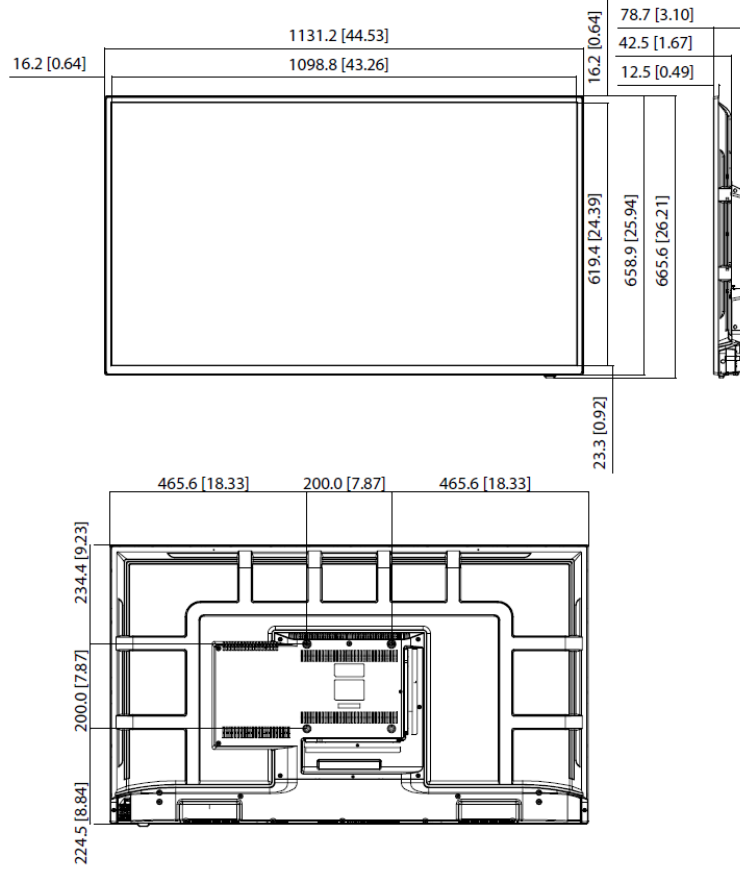

2.1.3 Dimensions (55-inch)

Figure 2-3 Dimensions (55-inch) (mm [inch])

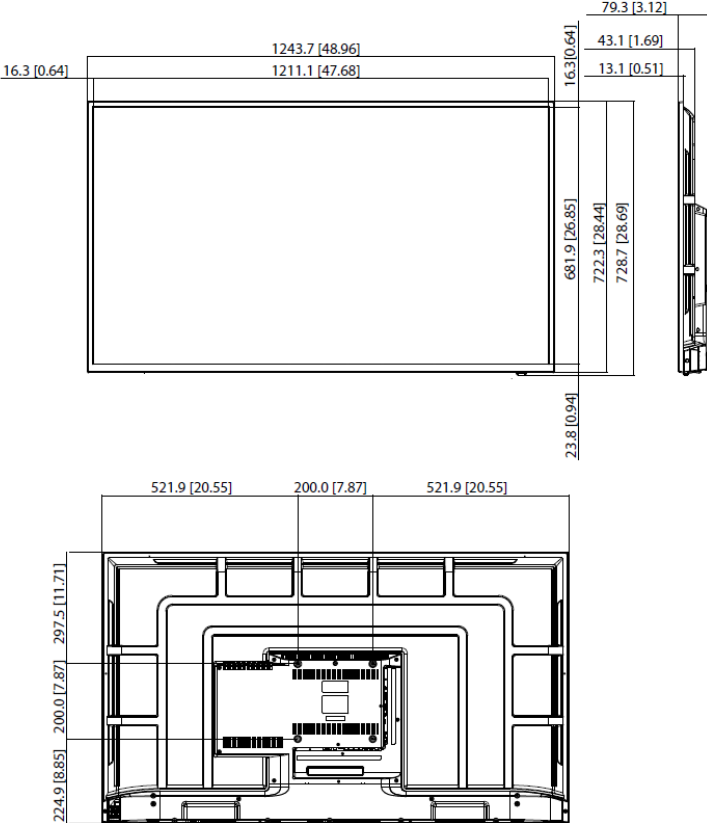

2.1.4 Dimensions (65-inch)

Figure 2-4 Dimensions (65-inch) (mm [inch])

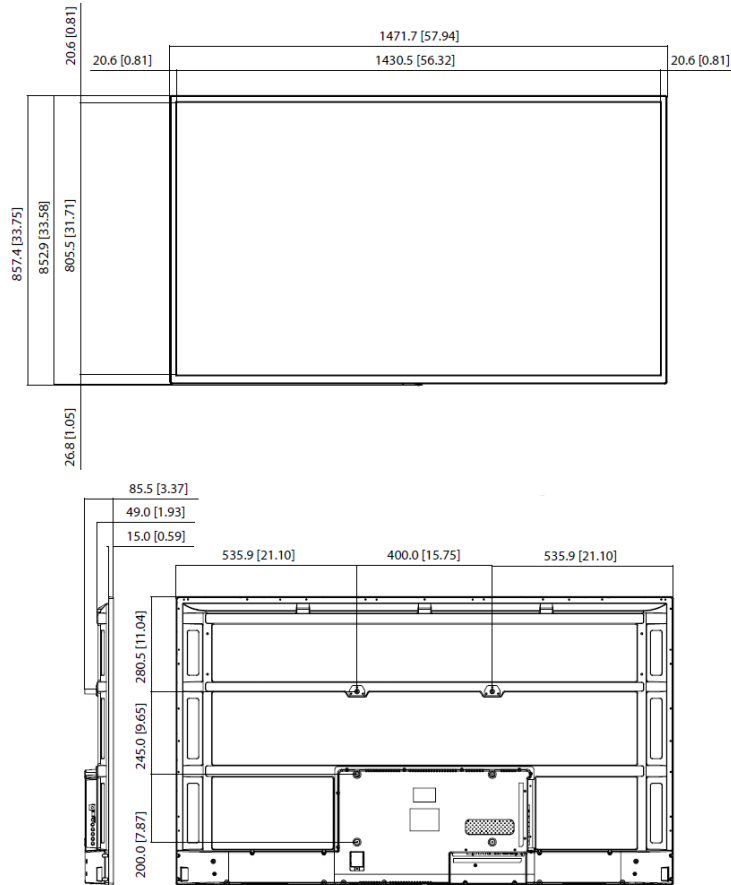

2.2 Ports

Slight difference might be found between different models. Here we use one signage as an example. Please refer to the actual device for detailed information.

Figure 2-5 Ports description

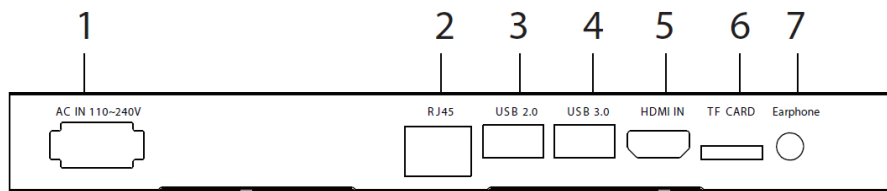

Table 2-1 Description of ports (wall-mounted signage)

No	Name	Description
1	Power input port	Inputs 100–240 VAC power.
2	RJ-45	Connects the Signage to the network through Ethernet cable.

No	Name	Description
3	USB2.0	Connects to devices such as mouse or USB drive.
4	USB3.0	Connects to devices such as mouse or USB drive.
5	HDMI IN	Inputs uncompressed HD video signals and multichannel audio signals from the external HDMI signal source.
6	TF card slot	Install the TF card.
7	Earphone	Outputs audio signals.

3 Installation

3.1 Installing the Signage

Procedure

- Step 1 Open the package, and then take out the Signage, bracket and 4 M6 × 12 screws.
- Step 2 Use 4 M6 × 12 screws to install the bracket on the back of the Signage.

Figure 3-1 Fix the bracket

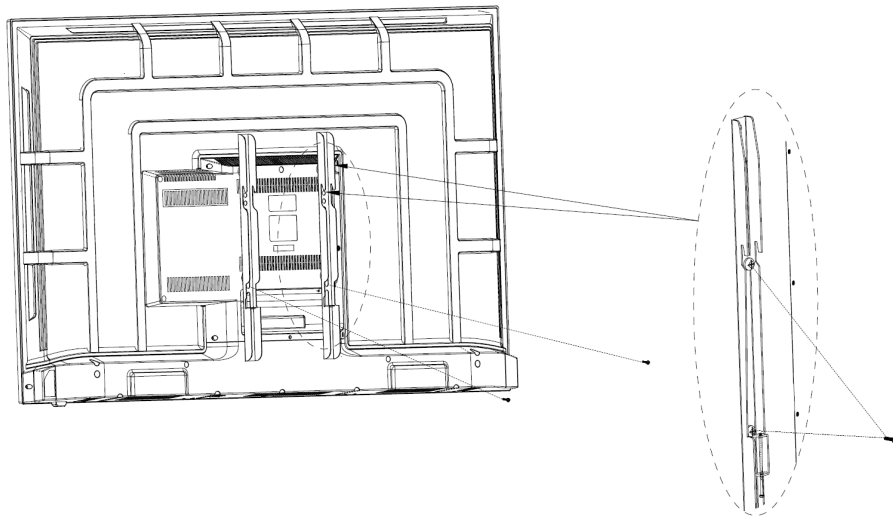

- Step 3 Install M5 × 100 screws on the vertical bracket.
Do not tighten the screws (leave 2 mm to 10 mm from the Signage) for later adjustments.

Figure 3-2 Install the screws

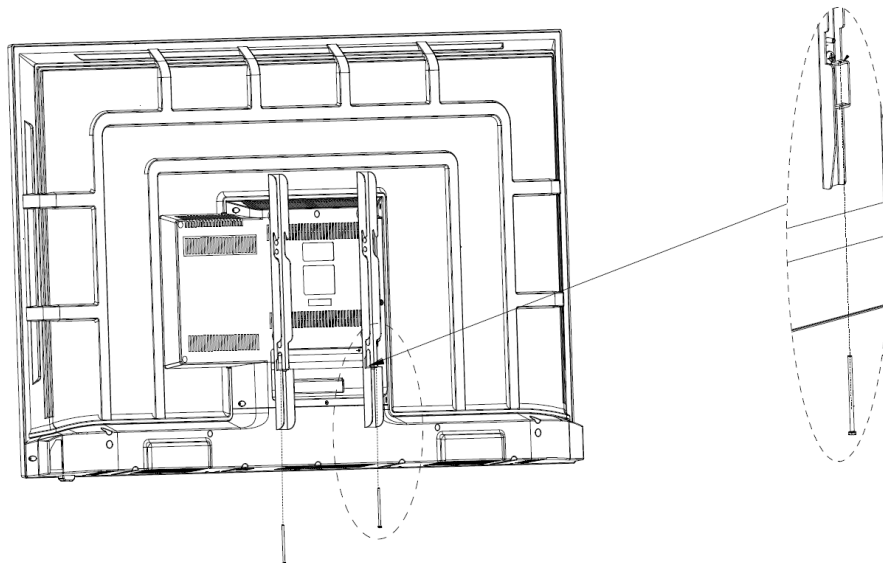

- Step 4 Mark screw locations on the wall, and then drill holes.
 1. Identify a suitable installation position, and then mark the screw locations.

2. Drill holes (dimensions: $\text{Ø}10$ mm; depth: above 65 mm) at the marked locations, and then put the expansion bolts into the holes.
3. Use M6 \times 50 screws to attach the horizontal bracket onto the wall and keep it horizontal.

Figure 3-3 Install the horizontal bracket

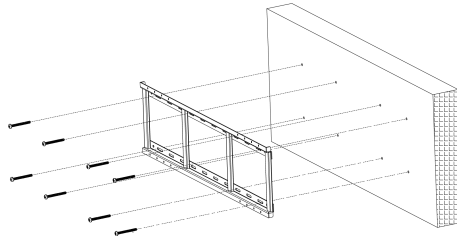

Step 5 Attach the Signage on the horizontal bracket.

Figure 3-4 Attach the signage

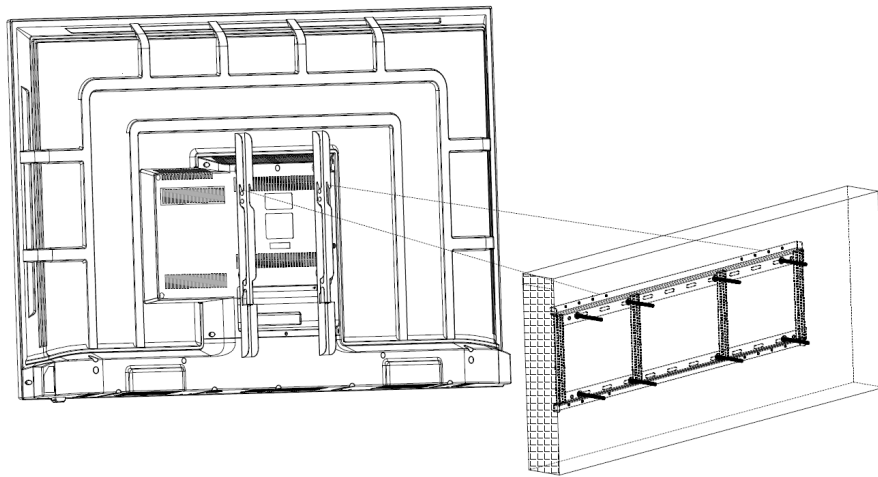

Step 6 Use M5 \times 100 screws to tighten the Signage.

Figure 3-5 Fix the signage

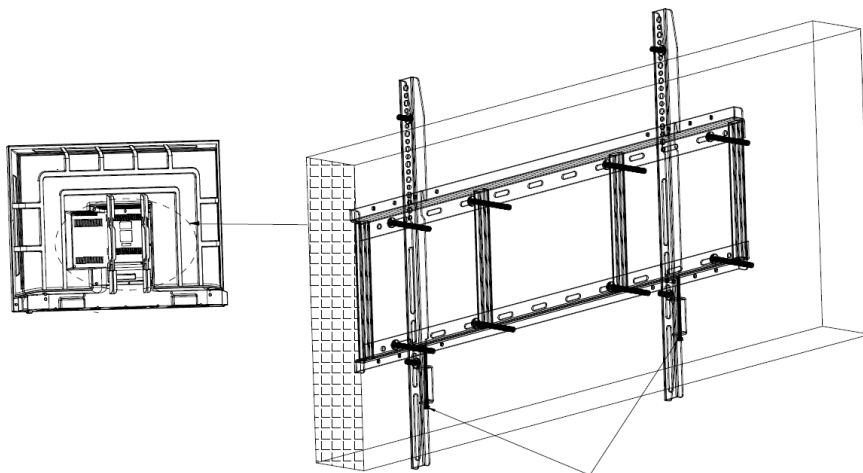

3.2 (Optional) Installing the Antenna

The position of the antenna port varies with the device. Generally, the port is located on the back panel or on the side panel. This section uses one of the devices as an example. For details, see the actual device.

Prerequisites

Prepare a Wi-Fi dongle.

Procedure

- Step 1 Check the installation area.
- Step 2 Unscrew the lid with a screwdriver.
- Step 3 Insert the Wi-Fi dongle, and then use 2 screws to fix it on the digital signage.

Figure 3-6 Install the antenna

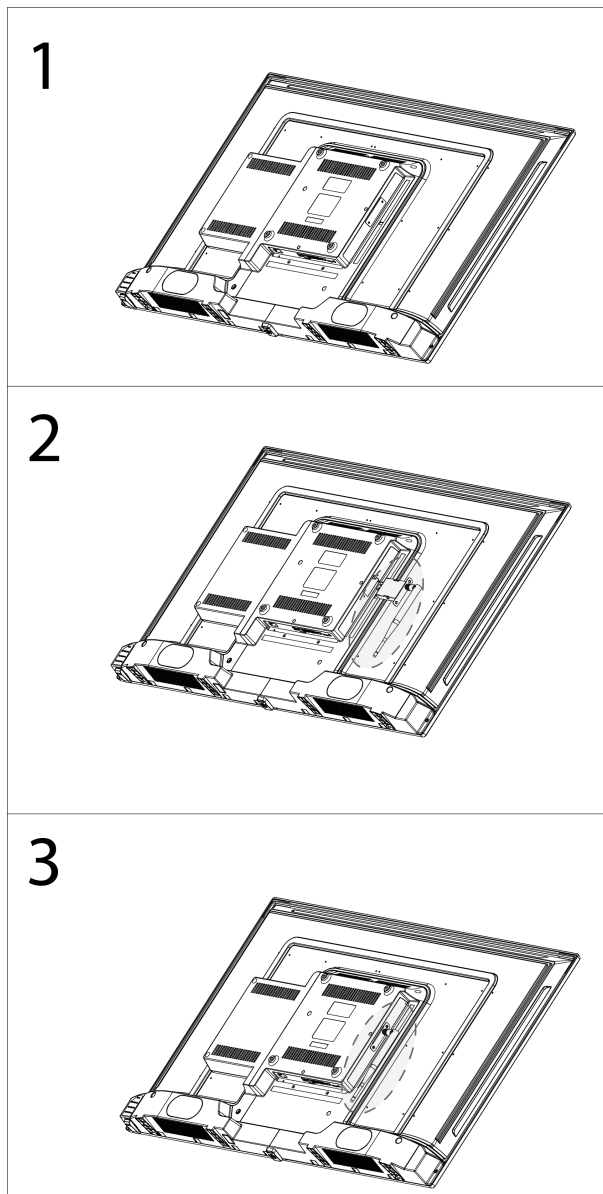

4 Basic Operations

The remote control supports limited operations: You can use the remote control to turn on or off the screen, turn on, turn off, or restart the Signage, adjust the volume and go back to the home page. We recommend you connect a mouse to operate the Signage. This chapter uses connecting a mouse for device operations as an example.



Wireless mouse is not supported to control the Signage.

4.1 Starting and Shutting Down



- Before starting the Signage, check whether the input voltage matches rated voltage of the Signage.
- To ensure stable operation and long service life of the Signage and external devices connected to the Signage, follow national standards and provide a power supply with stable voltage and low ripple interference.

Starting the Signage

Plug in the power cable of the Signage. The Signage starts.

Shutting down the Signage

Unplug the power cable. The Signage shuts down.

4.2 Initializing the Signage

For first-time use or after restoring the system to factory settings, you need to initialize the Signage. After that, you can start configuring and operating your device.

Procedure

- Step 1 Power on the Signage. The Signage starts.
- Step 2 Select the language and then click **Save and Next**.
- Step 3 Read the software license agreement, and then click **Next**.
- Step 4 Configure your password.
1. Enter your new password, and then confirm it.



The password must be 8–32 characters and contain at least two types from letters, numbers, and special characters.

2. Click **Confirm**.

Initialization starts.

Figure 4-1 Device initialization

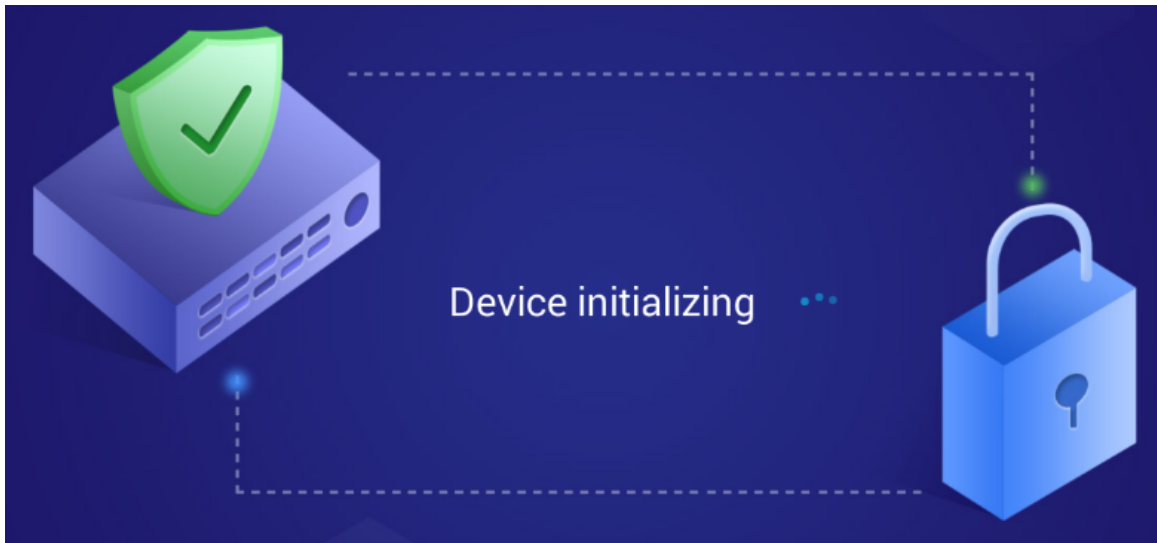

Step 5 On the **Password Protection** page, select questions, enter answers to the questions, and then click **Save and Next**.



Click **Skip** to skip setting security questions.

Figure 4-2 Password protection

Password Protection Skip Save and Next

Question 1 >

Answer 1

Question 2 >

Answer 2

Question 3 >

Answer 3

Step 6 On the **Terminal Info** page, configure device information.

1. Click  to set the name that identifies the Signage.
2. Click **Save and Next**.

Step 7 On the **Network Setting** page, configure the network.



Click **Skip** to skip setting the network.

1. Select network type as needed, and then configure the network.

Connect your device to network by Ethernet. Two methods are available to plan your device IP.

- DHCP: When there is a DHCP server on the network, after selecting the DHCP option, the Signage automatically obtains IP address from the DHCP server.
- Static IP: After selecting **Static IP**, respectively click **IP Address**, **Gateway** and **Netmask**, and enter the IP address, default gateway and net mask according to your network plan.

Figure 4-3 Network setting



2. Click **Save and Next**.

Step 8 On the **Platform Registration** page, register the Signage to the platform (MPS or ICC).



Click **Skip** to skip platform registration. Platform is required when multiple signages are used in a solution.

Figure 4-4 Platform registration

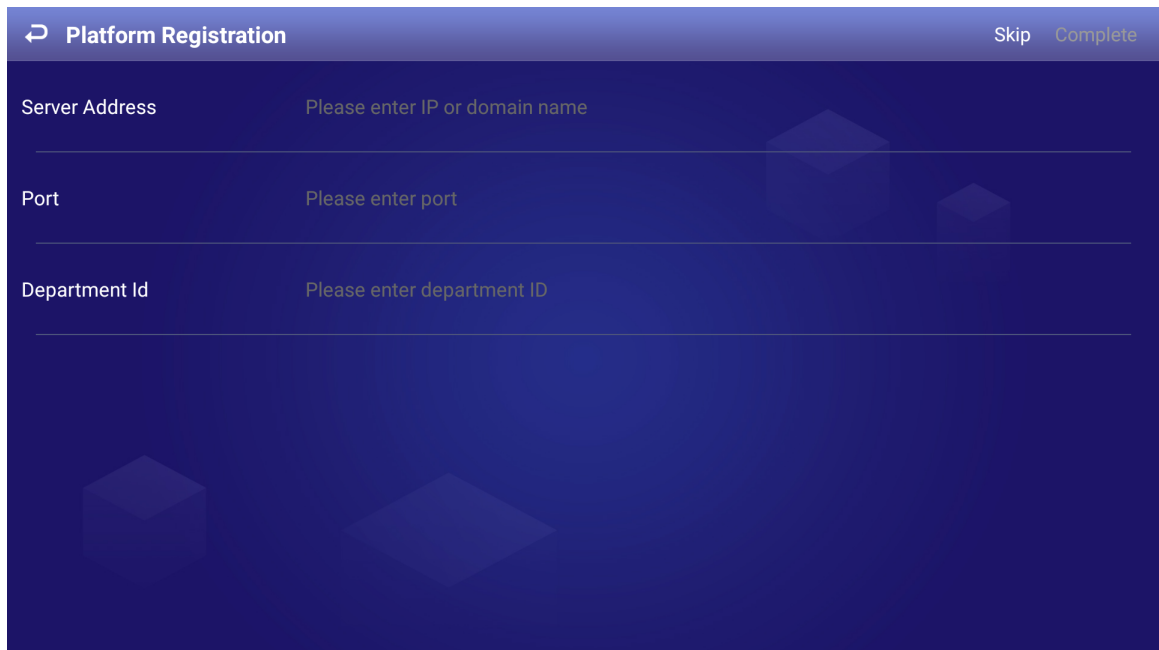

1. Enter the IP address or domain name, and the port of the platform (MPS or ICC).
2. (Optional) Enter the department ID.
3. Click **Complete**.

Figure 4-5 Main page

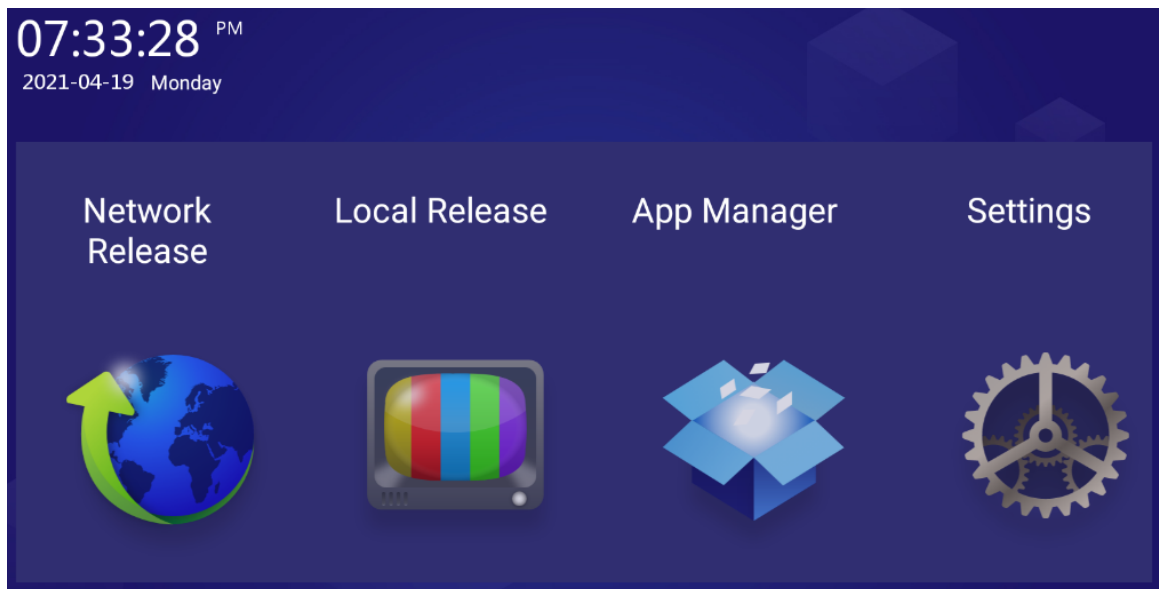

4.3 Login

You need to log in to the Signage for first-time use after initialization, or you lock the screen manually, or the screen is locked automatically after no operation is done for the defined time.

Procedure

- Step 1 Click any position on the screen.

Figure 4-6 Login

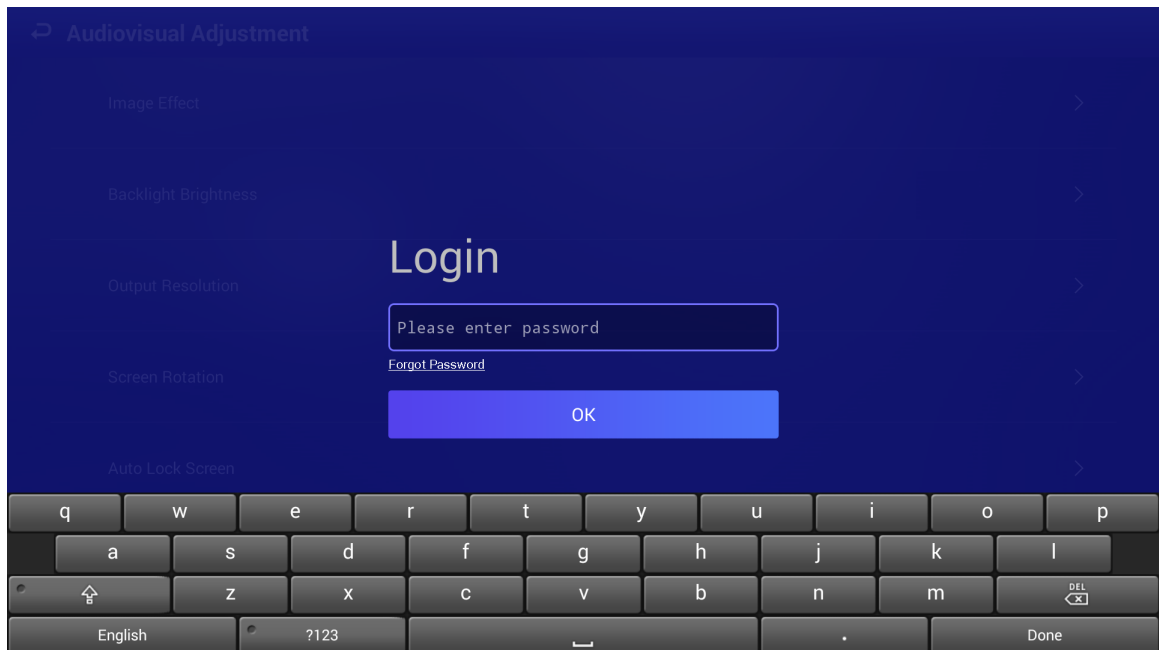

Step 2 Enter your password.



If you forgot your password, click **Forgot Password** to reset the password after answering the security questions.

Step 3 Click **OK**.

The main menu or the page before the system is locked is displayed.



- When the password is incorrectly entered, a note reminding you of the remaining tries will be displayed. You can try 5 times.
- After the password has been incorrectly entered for 5 times, the system displays **Account locked, restart or try 5 minutes later**.

4.4 Changing Password and Security Questions

We recommend updating the login password and security questions regularly to ensure device security.

4.4.1 Setting Password Validity Period

Procedure

Step 1 On the home page, select **Settings > Password Setting > Password Validity Period Setting**.

Figure 4-7 Password validity period setting

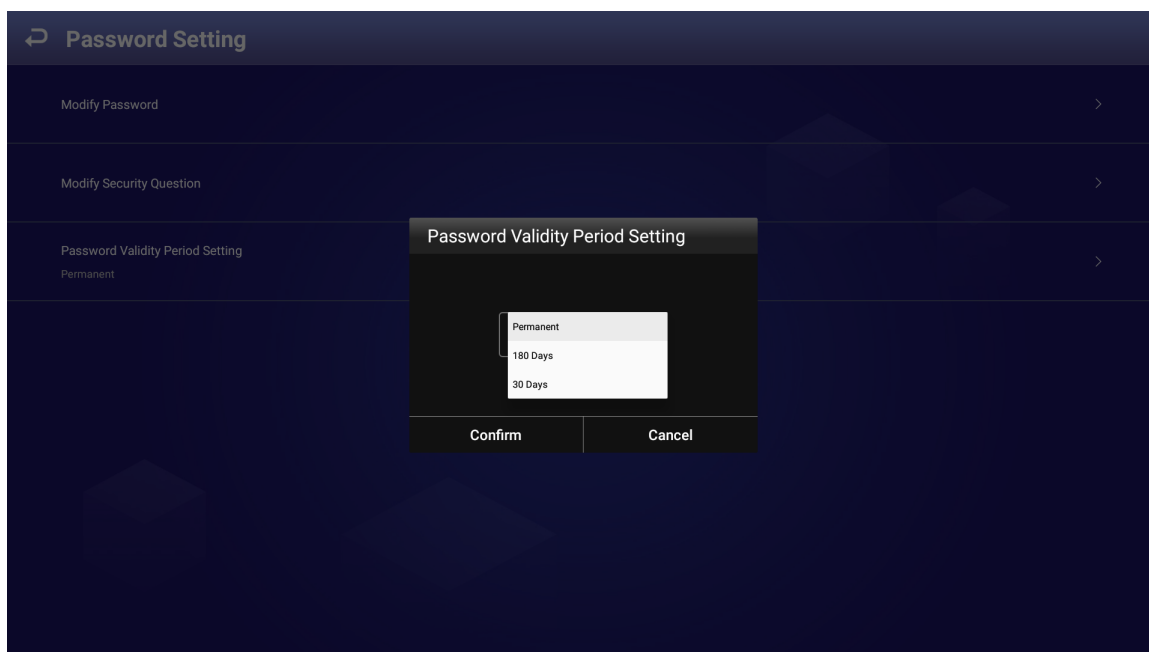

- Step 2** Select a password validity period. **Permanent** is selected by default.
- Step 3** Click **Confirm**.
- Step 4** (Optional) If the password remains unchanged after the validity period expires, the system will prompt you to change password. Click **Modify** to change the password immediately; click **Not Now** to log in without changing the password.

Figure 4-8 Password expired

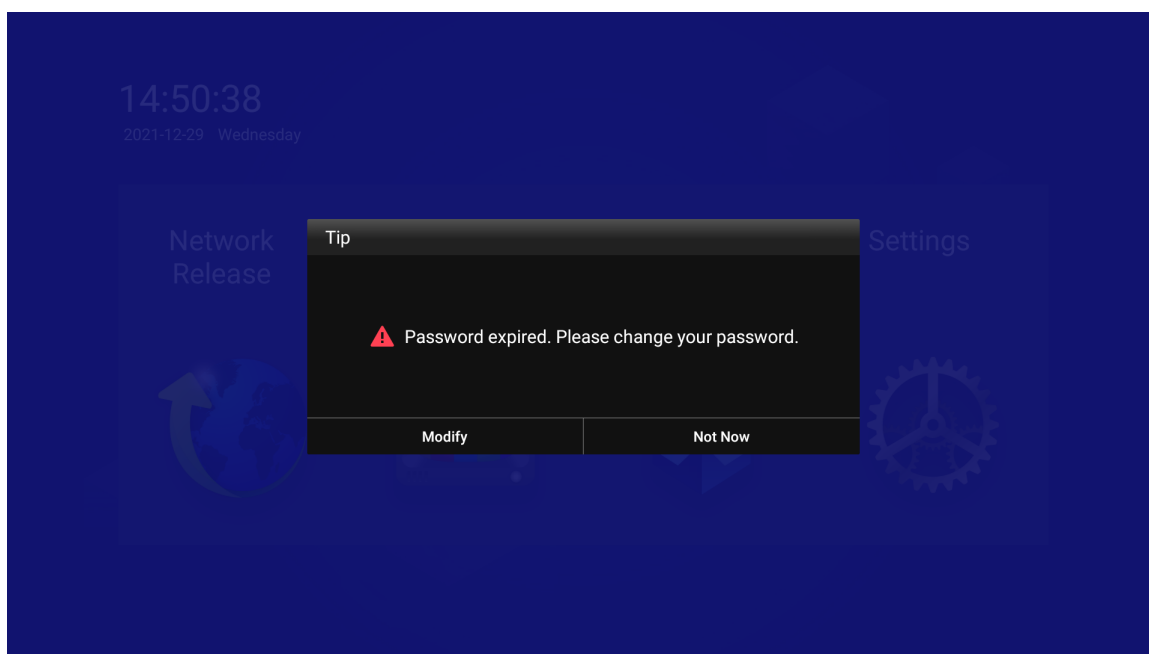

4.4.2 Changing Password

Procedure

- Step 1** On the main page, select **Settings** > **Password Setting** > **Password Setting**.

Step 2 Enter old password and new password, and then confirm your new password.

Step 3 Click **Save**.

Figure 4-9 Password settings

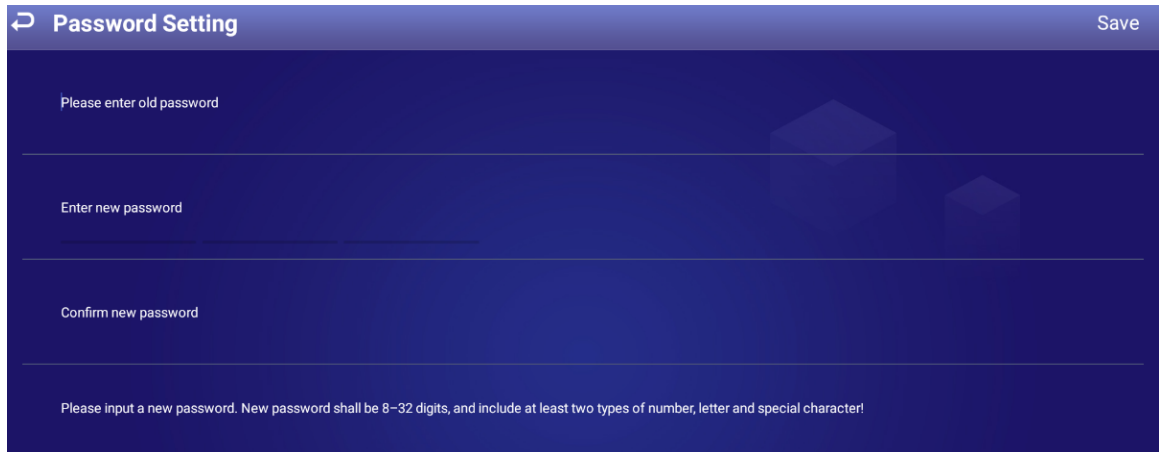

4.4.3 Changing Security Questions

Procedure

Step 1 On the main page, select **Settings** > **Password Setting** > **Modify Security Question**.

Figure 4-10 Modify security question

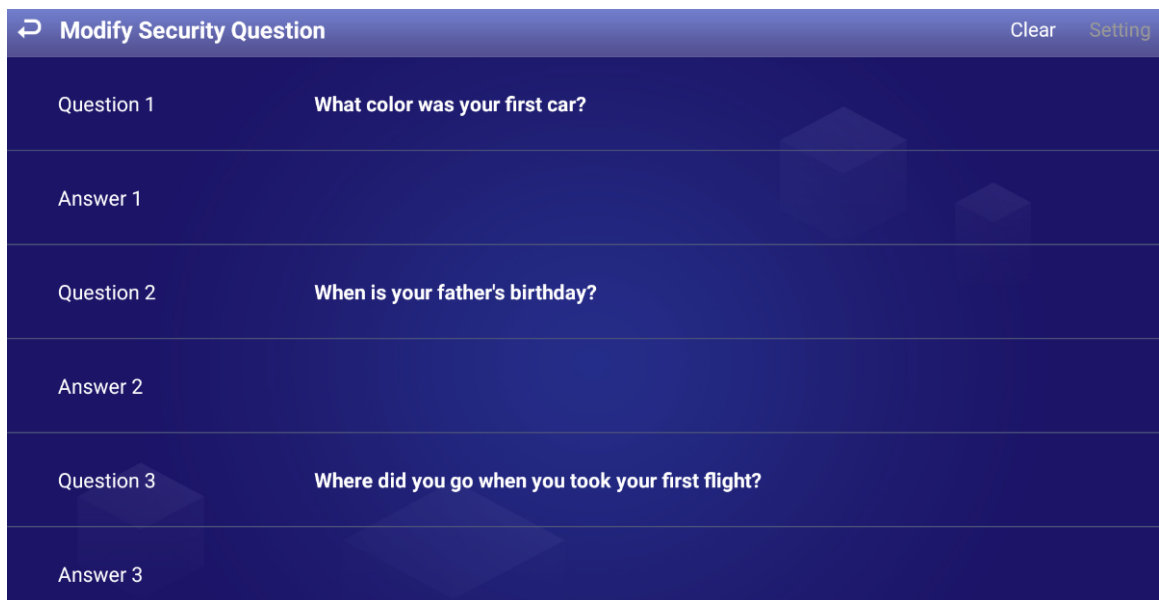

Step 2 Change answers to the security questions.



To change security questions, correctly answer the questions, and then click **Clear** to clear the answers first, and then set them again.

Step 3 Click **Setting**.

4.4.4 Resetting Password

Procedure

- Step 1 On the login page, click **Forgot Password**.
- Step 2 Enter answers to all the security questions.
- Step 3 Click **Confirm**, enter the new password, and then confirm it.

Figure 4-11 Verify security questions

Security Question Verify Confirm

Question 1 What color was your first car?

Answer 1

Question 2 When is your father's birthday?

Answer 2

Question 3 Where did you go when you took your first flight?

Answer 3





4.5 Quick Toolbar



Move your mouse pointer to the bottom of the page, and the quick toolbar will be displayed. You can perform operations including: Rotate the screen, adjust the backlight, select input source, go to quick play page, lock your screen, disconnect the USB drive from the Signage, and more.

Figure 4-12 Quick toolbar



Table 4-1 Description of quick toolbar

Icon	Description
	Displays whether the Signage is registered to the platform. This icon means not registered.
	Go to main page.
	Adjust the volume.
	Adjust the backlight.

Icon	Description
	Select input source from Local and HDMI . Different devices support different input sources.
	Lock the Signage.
	Disconnect your USB drive from the Signage.

4.6 Project Release

You can release projects locally or through the platform.

- Releasing projects locally is ideal for scenarios with a single required Signage.
- If multiple signages and media (pictures, videos) are involved, and network connection is available, we recommend releasing projects through the platform. This will facilitate central management of the Signage and media (pictures, videos).



You cannot release a project locally and through the platform at the same time. To release a project through the platform, stop playing local projects first.

4.6.1 Network Release

Release projects through the network. Register the Signage to the platform when you use network release for the first time.

4.6.1.1 Configuration Flow

Figure 4-13 Network release



Table 4-2 Configuration flow (network release)

Operation	Description
Log in	Log in and configure the Signage.
Configure network	Connects the Signage to the network.
Register the Signage to the platform	After registering the Signage to the platform, you can release projects and operate the Signage through the platform.
Release project through the platform	After adding media and configuring project plans on the platform, the project can be played on the Signage. For details, see the user's manual of the platform.

4.6.1.2 Configuring Network

4.6.1.2.1 Connecting the Signage to Network

Connect your Signage to the network by Ethernet. Also, after connecting the Signage to the network, it can be used as a hotspot for other digital signages.

Procedure

Step 1 On the main page, select **Settings** > **Network Setting**.



WLAN and **Portable hotspot** are available only when the signage installed Wi-Fi dongle.

Figure 4-14 Network setting (basic)

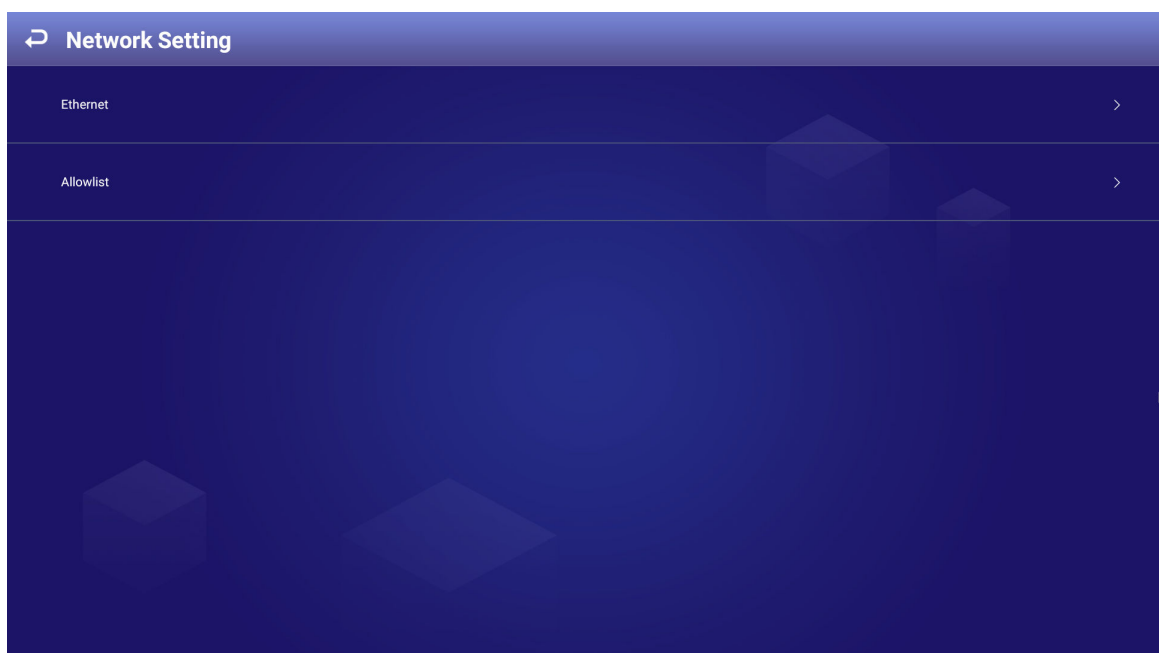



Figure 4-15 Network setting (with Wi-Fi dongle)



Step 2 Configure the network type that you want to use.

- Ethernet: Connect your device to the network by Ethernet. Two methods are available to plan your device IP.
 - ◇ DHCP: When there is a DHCP server on the network, after selecting the DHCP option, the Signage automatically obtains IP address from the DHCP server.
 - ◇ Static IP: After selecting Static IP, respectively click **IP Address**, **Gateway** or **Netmask**, and enter the IP address, default gateway and net mask according to the network plan.
- WLAN: Tap if Wi-Fi is available near the Signage. After turning on this function, you can connect your device to Wi-Fi in the following ways.
 - ◇ Auto search: Click a Wi-Fi, enter its password, and then connect.
 - ◇ Connecting to Wi-Fi manually: Tap  to manually add the Wi-Fi.

Related Operations

On the home page, select **Settings** > **Network Setting** > **Portable Hotspot**, and enable **Portable Hotspot**, then you can use your device as a hotspot for other devices.

Figure 4-16 Enable portable hotspot (1)

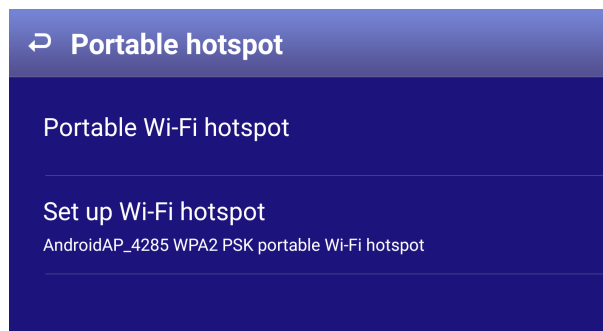
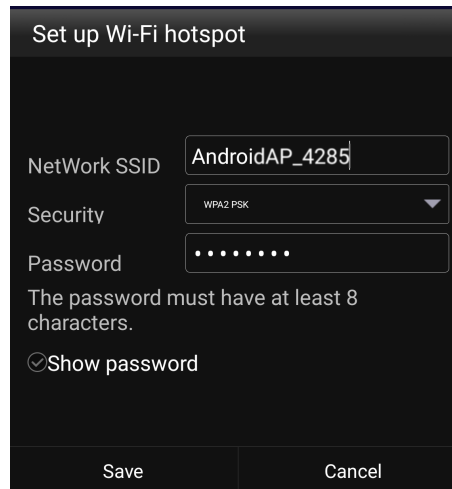

Figure 4-17 Enable portable hotspot (2)



1. Enable network SSID.
2. Select a security option, and then enter the password.
3. Click **Save**.

4.6.1.2.2 Configuring Allowlist

Configure IP addresses that are allowed to access the Signage. Only IP addresses in the allowlist can be used to log in to the web page. This is to enhance data security.

Procedure



- Step 1 On the main page, select **Settings** > **Network Setting** > **Allowlist**.
- Step 2 Click  to enable allowlist functions.  means enabled.
- Step 3 Add the IP address of target device to your allowlist.
1. Click .

Figure 4-18 Add allowlist



2. Enter an IP address.
3. Click **Confirm**.

The IP address that you have added is displayed.

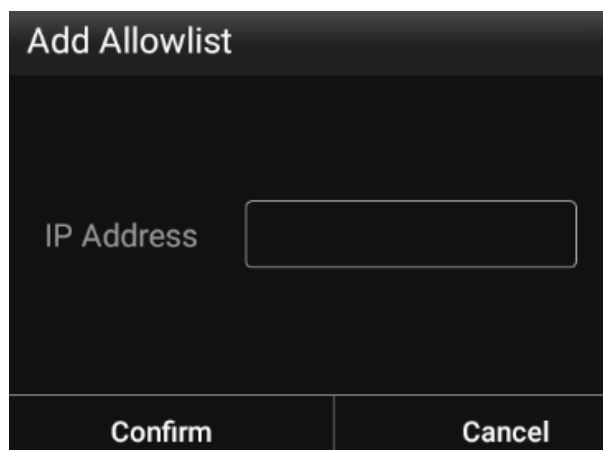

You can repeat the following steps to add multiple IP addresses to your allowlist.

4.6.1.3 Registering the Signage to the platform

Connect the Signage to the platform, and then you can release projects through the platform and play the projects on the Signage.

Prerequisites

- The Signage and the platform are connected to the same network.
- If allowlist is enabled, make sure that the IP address of the platform is added to the allowlist.

Procedure

Step 1 On the main page, click **Network Release**.

Move your mouse pointer to the bottom of the page, and then a floating toolbar is displayed. You can:



- Click  to import a project from USB drive.
- Click  to go back to the main page.
- View the status of registering to the platform.  means not registered.

Figure 4-19 Network release



Step 2 Click  on the lower-left corner.

Figure 4-20 Platform address

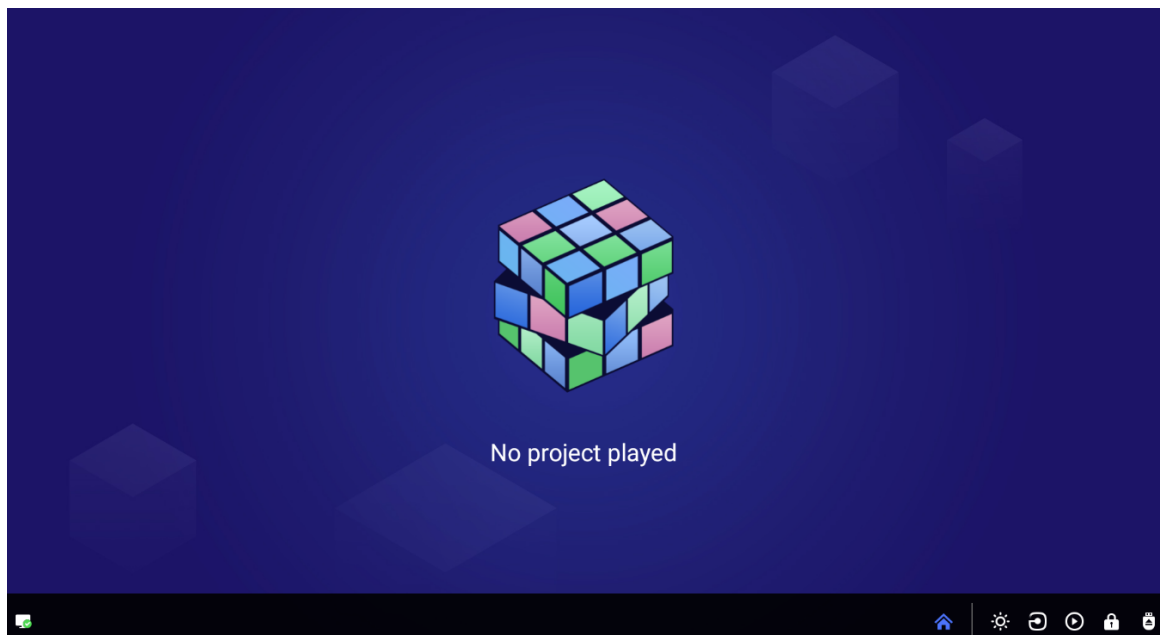

Step 3 Enter the IP address or domain name of the platform (MPS or ICC), the platform port and ID of the department that Signage is in.

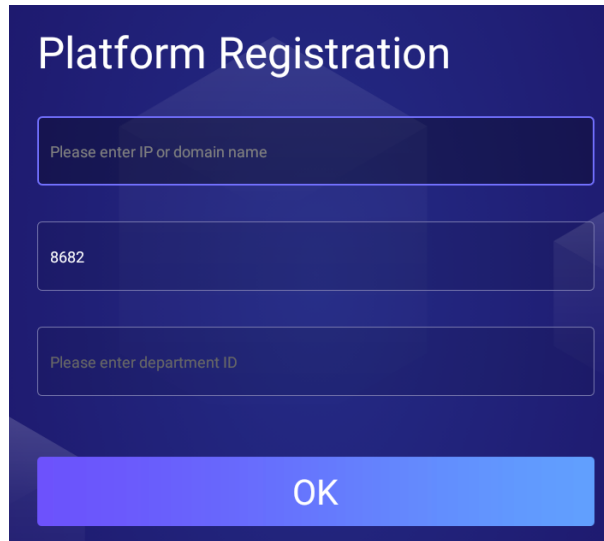

After registration, you can only link the Signage with devices in the same department. For details about operations on the platform, see the corresponding user's manual.

Step 4 Click **OK**.

After successful registration, the icon on the lower-right corner changes to .

4.6.1.4 Releasing Project

Manage signages and release projects through the platform. For details, see the user's manual of the platform.

4.6.2 Local Release

Add videos or pictures to projects, and release projects locally by using **General** or **Special** template.

- For **General** template, you can select from **Quick Play** and **Customized Play**.
- For **Special** templates, you can select from **Catering & Life**, **Special Offer & Promotion**, **Brand Publicity**, **Supermarket & Hotel**, **Info & News**, **Face Attendance**, **Stream Media**, and **Video Surveillance**.

4.6.2.1 Configuration Flow

Figure 4-21 Local release (general template)

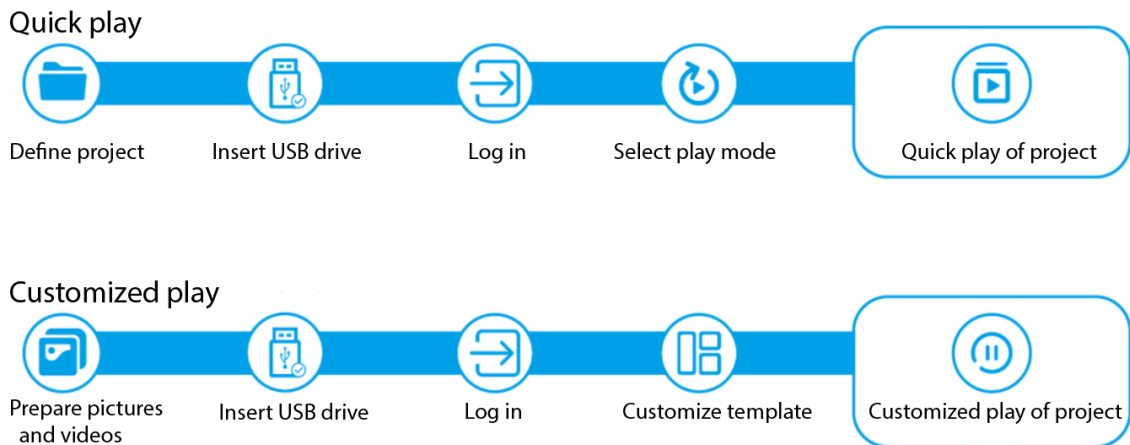
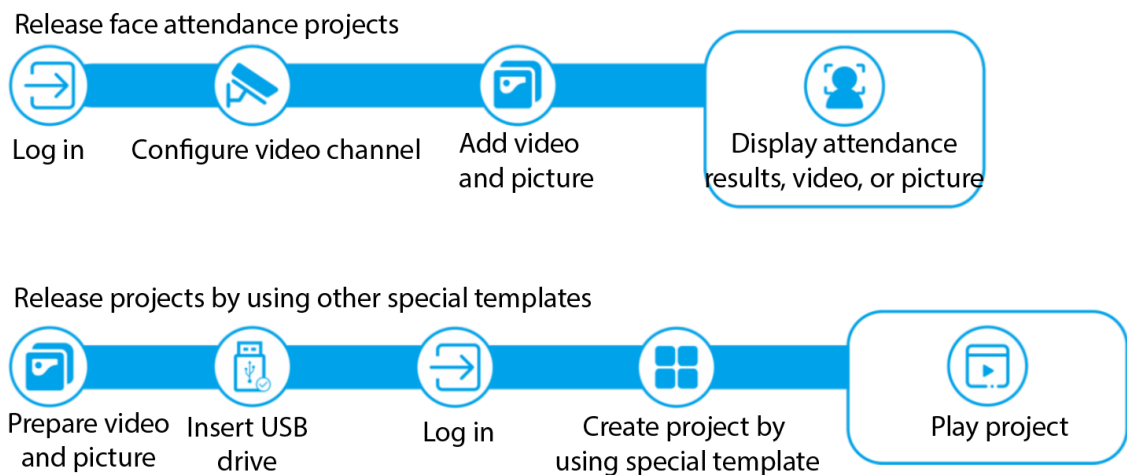

Figure 4-22 Local release (special template)



4.6.2.2 Releasing Projects by General Templates

4.6.2.2.1 Quick Play

Use the given templates to quickly release projects.

Prerequisites

- The USBPLAY folder is created on the USB drive.
- Insert the USB drive with media to be played into the Signage. Make sure that the pictures and videos are saved in the root directory of the USBPLAY folder.

Procedure

Step 1 On the main page, select **Local Release** > **General** > **Quick Play**.

Figure 4-23 Quick play

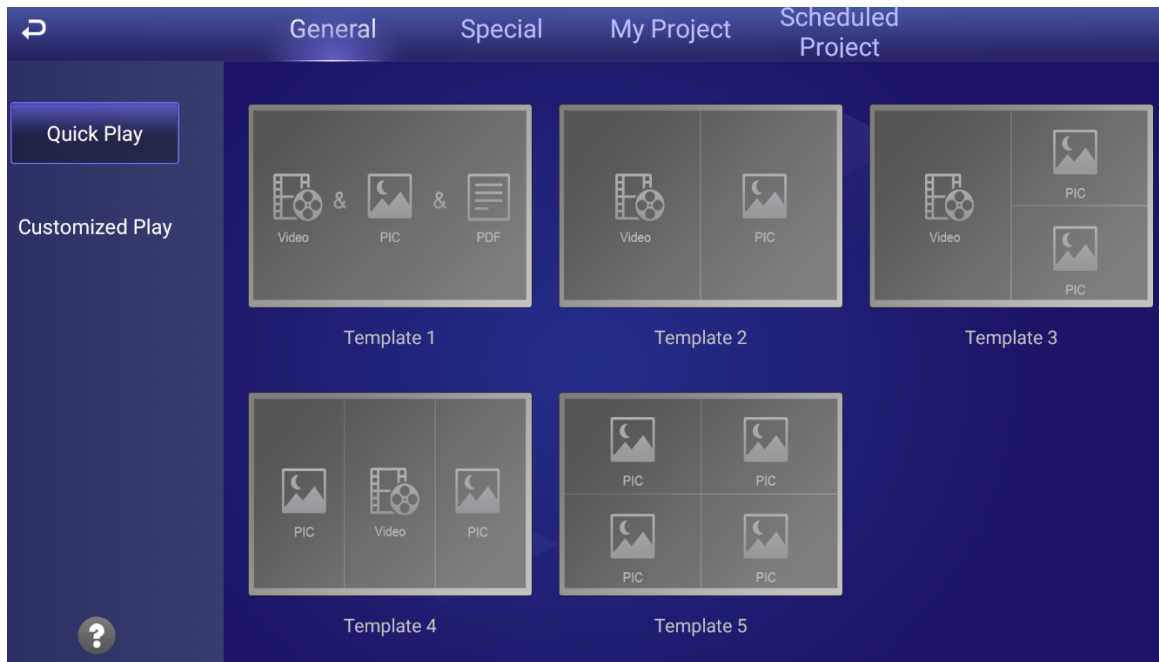

Step 2 Select a template.

The system will display pictures and videos according to their layout in the template. A picture is displayed for 10 seconds by default and a video to the end.

4.6.2.2.2 Custom Play

Define your own templates to release information.

Procedure

Step 1 On the main page, select **Local Release** > **General** > **Custom Play**.

Figure 4-24 Customized play



Step 2 Click a template that you want to define.

Step 3 Define the template.

1. Click  to configure this region's display sequence and content.

Figure 4-25 Add media

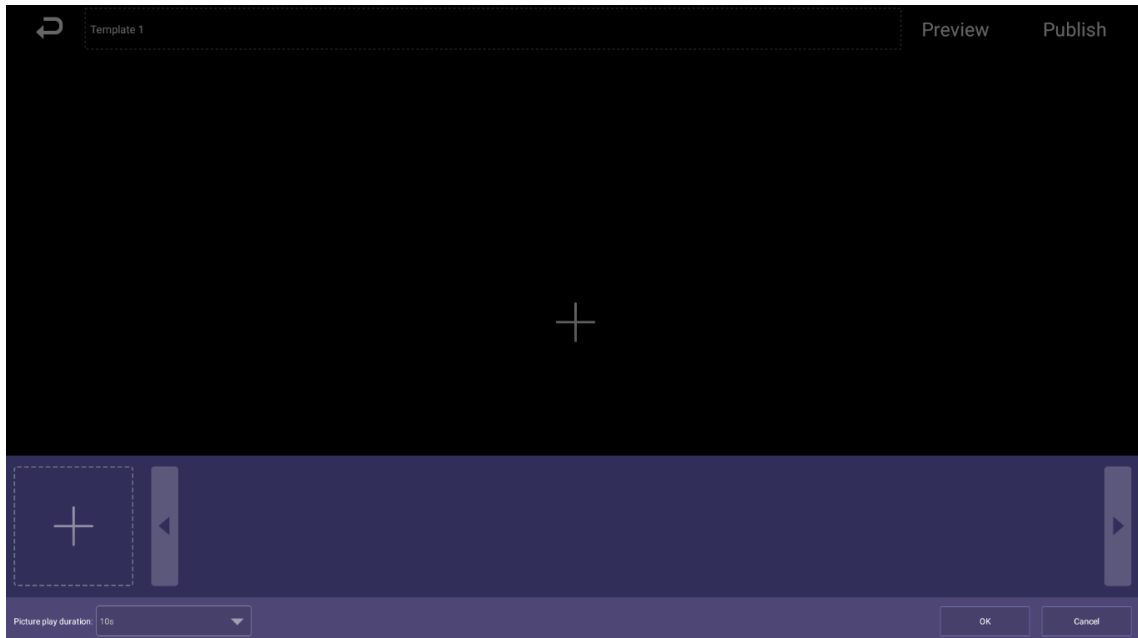

2. Click .
3. Select a picture or a video, and configure the picture play duration as needed.



- Pictures are displayed for 10 seconds by default and videos to the end.
- You can repeat the following steps to upload multiple pictures or videos. After adding the media (pictures and videos), you can drag the media to sort them.

4. Click **OK**.

If there are multiple regions in your template, to make the template effective, you need to add projects to other regions.

Step 4 (Optional) Click **Preview** to preview the project to be played.

Step 5 Click **Publish** to play your project immediately.

4.6.2.3 Releasing Projects by Special Templates

Special templates include **Catering & Life**, **Special Offer & Promotion**, **Brand Publicity**, **Supermarket & Hotel**, **Info & News**, **Face Attendance**, **Stream Media**, and **Video Surveillance**. Select template as needed.

4.6.2.3.1 Configuring Face Attendance Template

Add a camera channel to the Signage, and then the face information captured by the camera will be displayed, such as the similarity between the faces captured and faces saved in the database, and capture time.

Prerequisites

- When connecting your camera and the Signage through DSS or PSS protocol, make sure that a registration code is assigned to the Signage by the DSS platform or the Smart PSS client. When you have done this, your signage will successfully connect to the platform or client.
- The Signage, your camera, and the platform (for example DSS) are connected to the same LAN (Local Area Network).
- Your camera supports face detection and face comparison, and face database is configured.

Procedure

Step 1 On the main page, select **Local Release** > **Special**.

Step 2 Click the **Face Attendance** template.

Figure 4-26 Configure face attendance template

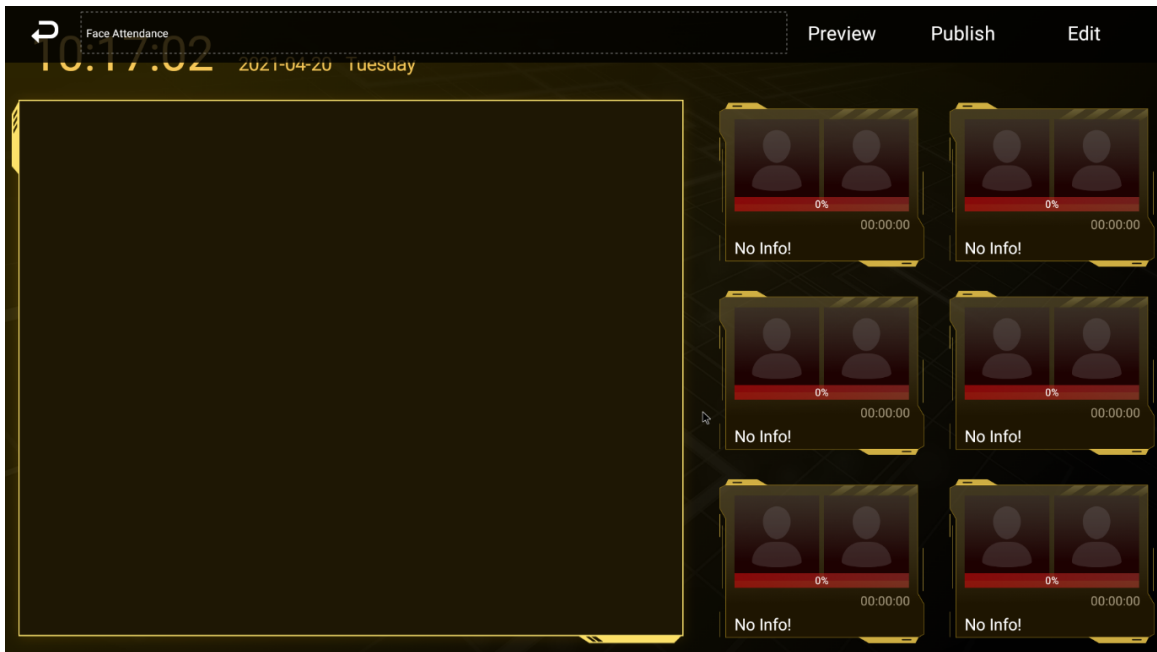

Step 3 Click **Edit** on the upper-right corner.



- You can add video channels, video recordings and pictures to the template.
- Only one kind of media can be played at the same time.

Step 4 Add a channel, and then configure other parameters.

Figure 4-27 Setting

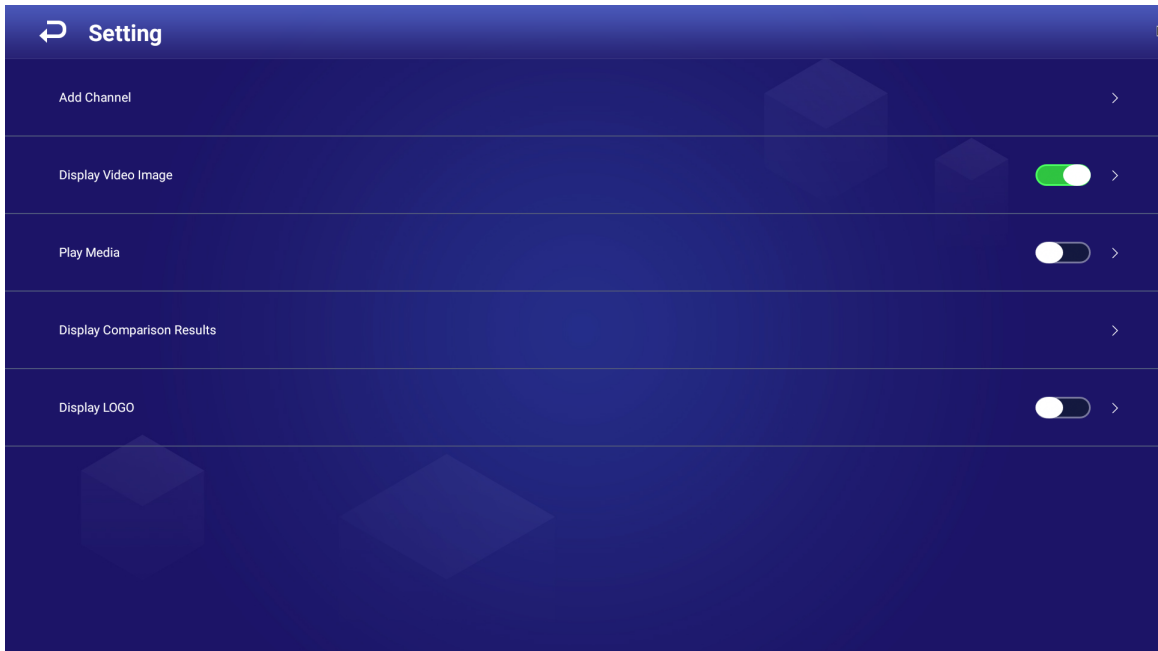

Click **Add Channel**, and then configure channel parameters.

Figure 4-28 Add channel

Add Channel

Protocol Acquisition ▼

IP Address

Username

Password

Port

Channel

Stream Type Main Stream ▼

Confirm
Cancel



Table 4-3 Description of adding channel







Parameter	Description
Protocol	You can select from Acquisition (IP camera, IVSS (intelligent video surveillance server)), DSS , and PSS (SmartPSS), depending on the device connected.
IP Address	IP address of device (IP camera, IVSS), DSS, or PSS, depends on the Protocol that you select.

Parameter	Description
Username	Username and password for logging in to IP camera or IVSS.
Password	 <p>You need to enter the username and password when Acquisition is selected from Protocol.</p>
Port	<p>Port for logging in to IP camera, IVSS, DSS, or PSS.</p> <p>It is 37777 by default for IP camera and IVSS, and 8101 for DSS and PSS.</p>
Channel	<p>You need to enter channel No. when IP camera or IVSS is connected.</p> <ul style="list-style-type: none"> ● Enter 1 when IP camera is connected. ● Enter the number of channels that you want to display when IVSS is connected.
Stream Type	<ul style="list-style-type: none"> ● Main stream: Provides large bit stream and images with high resolution, but requires large bandwidth. ● Sub stream: Provides small bit stream and smooth image, and requires less bandwidth.

Step 5 Click **Confirm**, and then configure other parameters.

Table 4-4 Description of other parameters

Parameter	Description
Display Video Image	<ul style="list-style-type: none"> ● Screen s plit: You can view the video image of the added channels by 1, 2, 3, or 4 splits. ● Switching time(seconds) : Switch to play video of another added channel after the defined time. ● Channel selection : Select the channel to be played in each screen split.
Play Media	<p>Click  to add media (video or picture).</p>  <ul style="list-style-type: none"> ● Select media, and then click  to delete it. ● Drag the media to sort them. ● Pictures are displayed for 10 seconds by default and videos to the end. ● Only one kind of media can be played at a time.

Parameter	Description
Display Comparison Results	<p>Enable or disable voice broadcast and temperature information and display face comparison results.</p> <ul style="list-style-type: none"> • Voice broadcast: Click  to enable voice broadcast. • Display successful comparison results: Click , and then select the item to be displayed when face comparison succeeds. • Display failed comparison results: Click , and then select the item to be displayed when face comparison fails. • Display card number: After registering the certificate number (such as ID No., passport No.) of person on the platform, if Display Card Number is enabled, such information will be displayed next to the person name on the Signage. • Temperature: Click  to enable temperature . <p></p> <p>The temperature function is available only when the Signage is associated with the turnstiles from the same manufacturer.</p>
Display LOGO	Click  to add a picture, which will be the logo displayed on the upper-right corner when face attendance project is played.

Step 6 (Optional) Click **Preview** on the upper-right corner to preview the project to be played.

Step 7 Click **Publish** on the upper-right corner to play your project immediately.

4.6.2.3.2 Configuring Other Special Templates

The other special templates are similar in configurations. This sections uses supermarket & hotel template as an example.

Procedure

Step 1 On the main page, select **Local Release** > **Special**.

Step 2 Click a template that you want to define.

Step 3 Configure the template.

1. Click  to configure this region's display sequence and content.

Figure 4-29 Add media



2. Click .
3. Select a picture, and configure the picture play duration as needed.



- Pictures are displayed for 10 seconds by default and videos to the end.
- You can repeat the following steps to upload multiple pictures or videos. After adding the media (pictures, videos), you can drag the media to sort them.
- Click  to delete media.
- Click **OK**.

If there are multiple regions in your template, to make the template effective, you need to add projects to other regions.

Step 4 Operate the template that you have almost finished. On the upper-right corner of the current page.

- Click **Preview** to preview the project to be played.
- Click **Publish** to play your project immediately.

4.6.2.3.3 Importing Templates from the Platform

Import templates created by the platform to quickly release projects. Supports to import the media at the same times.

Prerequisites

Already exported the template from the platform. If you choose to export media at the same time when exporting a template, the exported file contains both the template and media.

Procedure

Step 1 Import the template created by the platform.

1. Create a new folder named **TEMPLATE** on the USB drive.
2. Copy the files exported from the platform to the **TEMPLATE** folder.

3. Select **Local Release** > **Special**, and then click  on the lower-right corner.
4. On the pop-up page, click **Confirm**. The signage starts to importing the platform.

Step 2 Click the imported template, and then edit it.

The imported template shows  on the upper-right corner.

Figure 4-30 Template imported from the platform

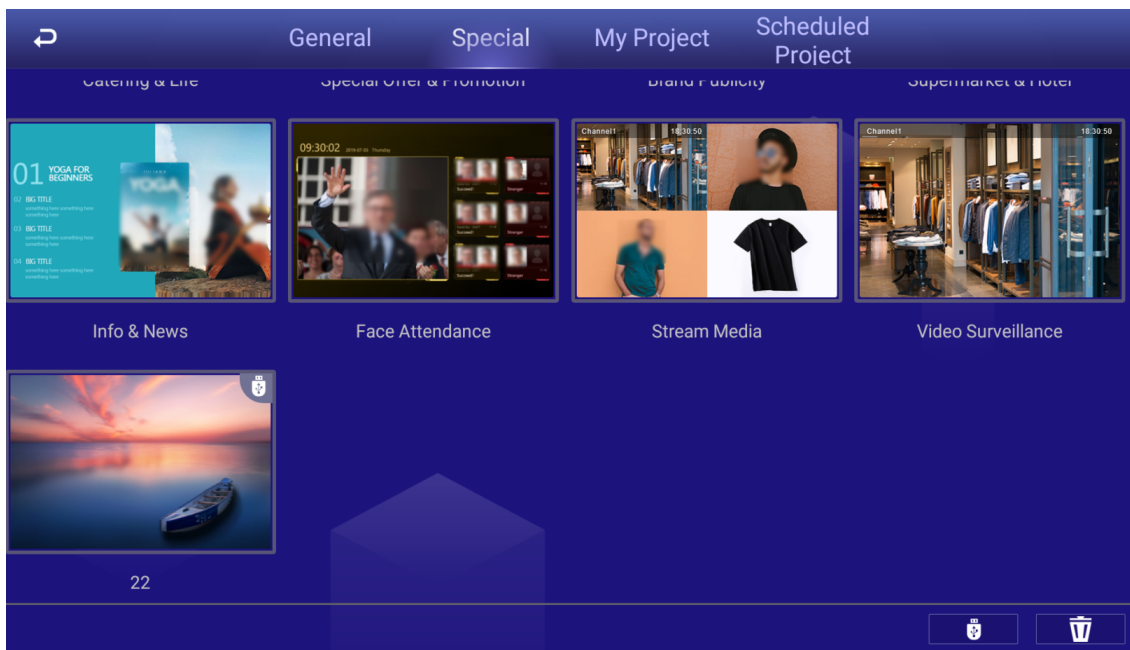

Supports to modify the name of the template. Click  to add more media.

Figure 4-31 Edit the template



Step 3 Click **Preview** to preview the added media.

Step 4 Click **Publish**, the system displays the configured project.

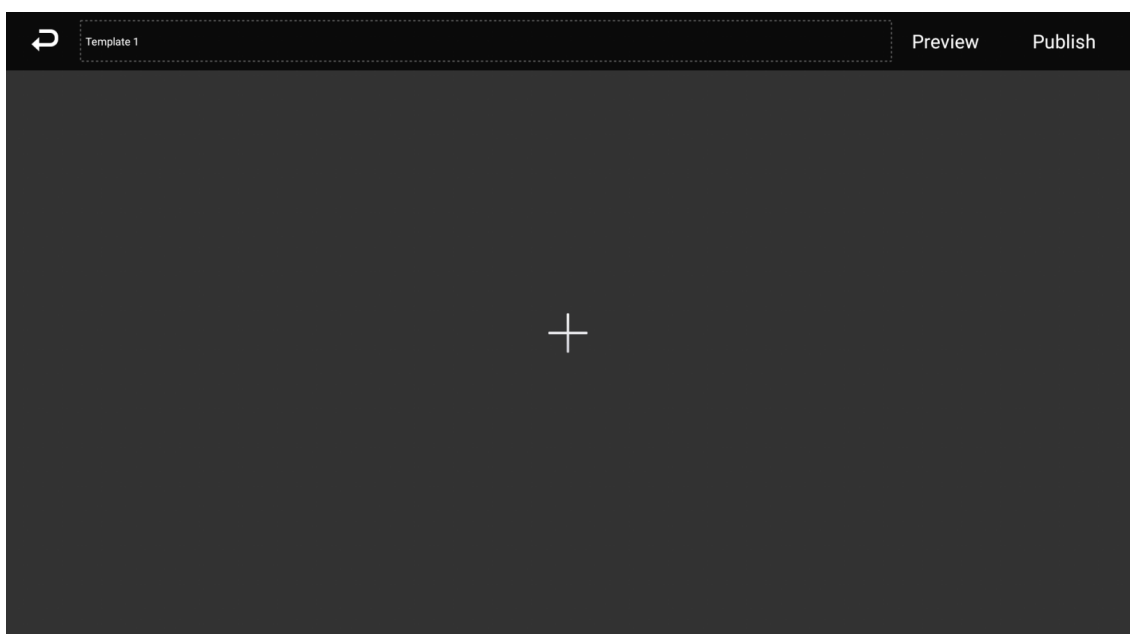
4.6.2.4 Managing My Project

On the main page, select **Local Release** > **My Project**, and then you can view projects that have been played and the templates you have saved.

You can also:

- View played projects and saved templates.
- Click a project to play it.
- Click , and then select a project to delete this project.

Figure 4-32 My project



4.6.2.5 Scheduled Project

4.6.2.5.1 Customizing Scheduled Project

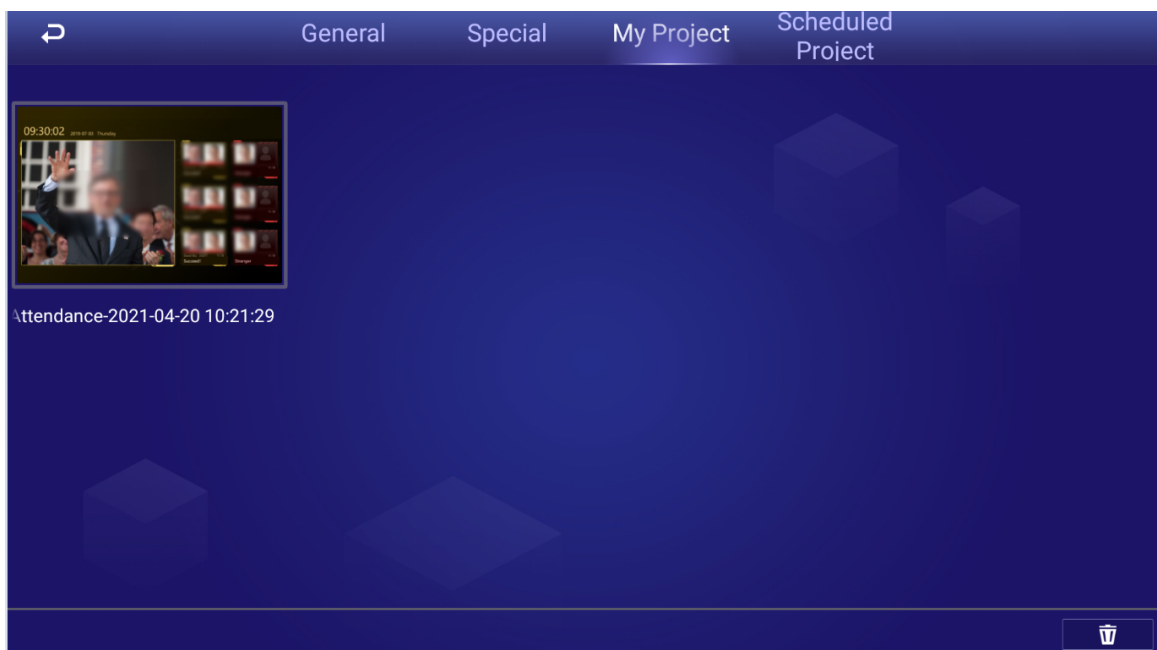
Configure which and when projects will be played.

Procedure

- Step 1 On the main page, select **Local Release** > **Scheduled Project**.
- Step 2 Click , and then on the page displayed, click **Add order play period**.

Figure 4-33 Add order play period



- Step 3 Set time period, and then click .

Figure 4-34 Add order play period

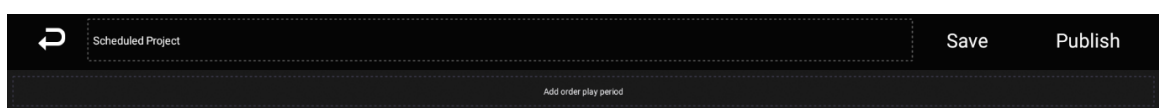

Step 4 Click , select a project, and then click **OK**.

The system goes back to the **Add Project** page.



Up to 30 projects can be added to each time period.

Figure 4-35 Add project

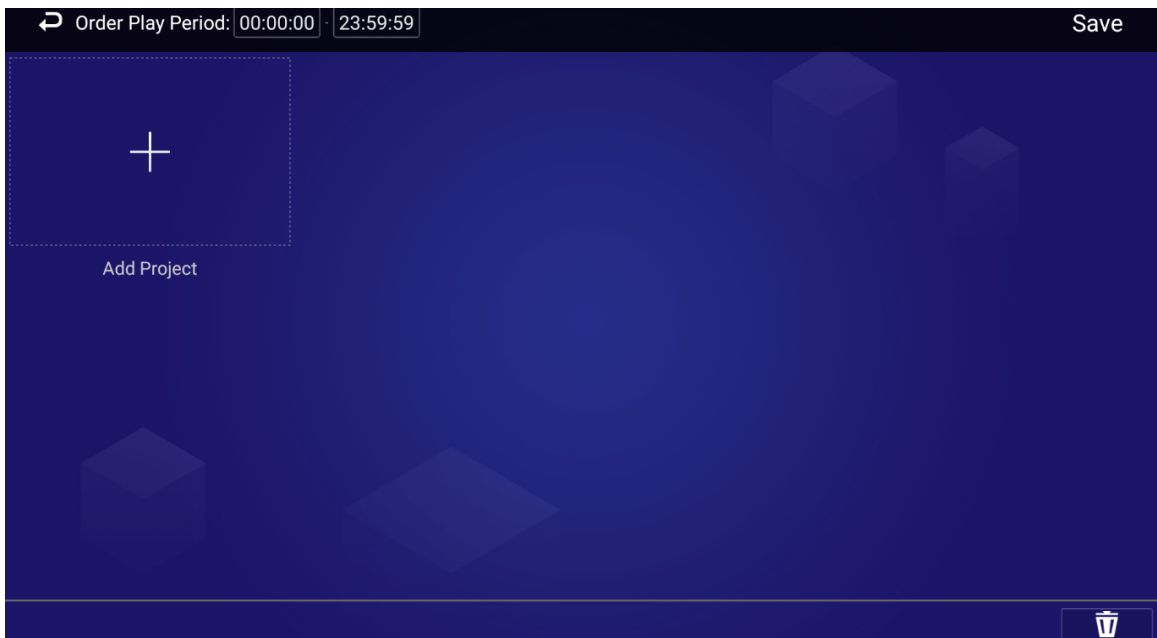

Step 5 Click **Save**.

The system goes back to the **Add order play period** page.



Up to 30 periods can be added.

Step 6 Click **Save**.



You can also click **Publish** to play the project immediately.

4.6.2.5.2 Importing Project from the Platform

Prerequisites

Already exported projects from the platform.

Procedure

- Step 1 Create a new folder named **DAILYPLAN** on the USB drive.
- Step 2 Copy the project exported from the platform to the **DAILYPLAN** folder.
- Step 3 Insert the USB drive to the signage, and then import the project.
- Step 4 Click the imported project to check the information.

The imported project shows  on the upper-right corner.

- If the imported project is expired, the project details cannot be viewed.
- If the current time is within the scheduled time, the signage jumps to the network release page to display the specific project.
- If the current time is not in the scheduled time, the signage jumps to the network release page, but no project will be displayed.

4.7 App Manager

On the main page, click **App Manager**, and then the **App Center** page is displayed.

You can:

- Click the **App Center** tab to install new apps, view and manage different files, search for and download media (pictures, videos).
 - ◇ Click **Install App** to install new apps.
 - ◇ Click **File Manager** to view and manage different files.
- Click the **App Uninstall** tab to uninstall the app from the Signage.
- Click the **Boot App** tab to set the application to start automatically when the signage starts.

Figure 4-36 App center

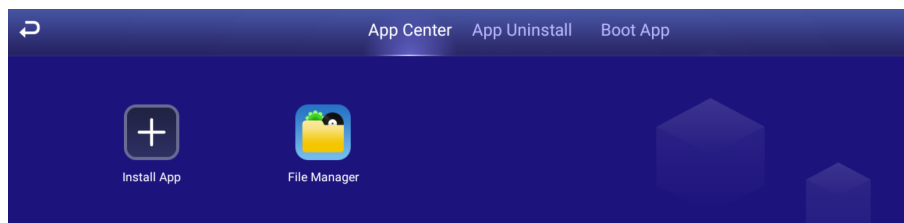

4.7.1 Installing App

Install an app to the Signage, and then you can manage and operate the app.

Prerequisites

Insert the USB drive with the installation package (.apk) into the Signage.

Procedure

- Step 1 On the main page, select **App Manager** > **App Center** > **Install App**.

Figure 4-37 Select location

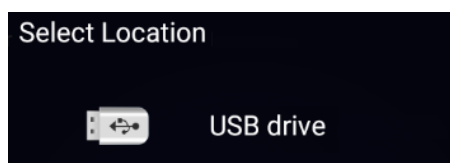

- Step 2** Click the USB where the installation file is installed.
The system will automatically find an app file for you.

Figure 4-38 Install an app

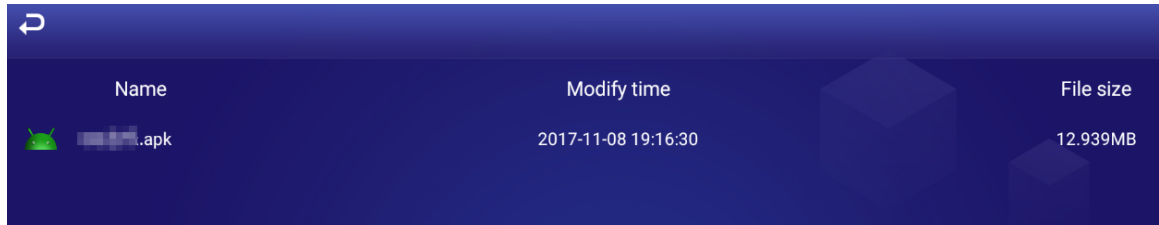

- Step 3** Click the installation file.
The system prompts **Allow install xxx.apk application?**
- Step 4** Click **OK**.
The installation starts. Follow the onscreen instructions to finish the installation.
You can use and view the app you have installed in **App Center**.

4.7.2 File Manager

View and manage different types of files.

Procedure

- Step 1** On the main page, select **App Manager > App Center > File Manager**.

Figure 4-39 File manager

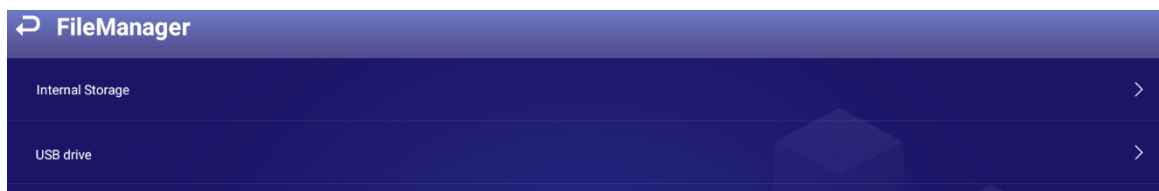

- Step 2** Select a storage path, for example, internal storage.
Files are displayed in different types.
Click a file type to view and operate (such as delete) files.

Figure 4-40 Different types of files

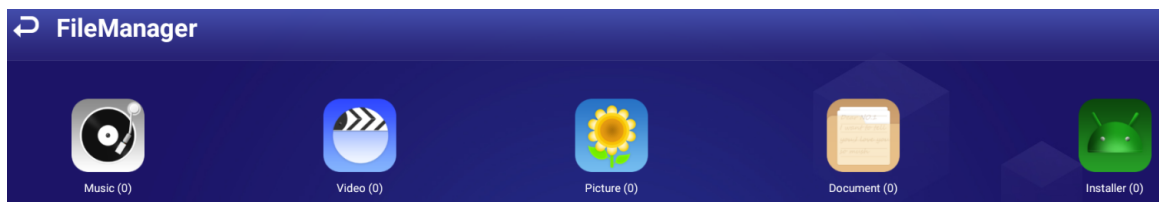

5 System Settings

5.1 Setting Date & Time

You can set time and date for the Signage. Remember to select a correct time zone based on where the Signage lies.

Procedure

- Step 1** On the main page, select **Settings** > **Date & Time**.
- Step 2** Set date, time, and time zone. You can also enable the 24-hour format.
The operation takes effect immediately.
- Step 3** Enable IPC time setting, configure the **Renewal cycle** (24 hours by default), and then click **Save**. The time of IPC will be synchronized with that of the Signage within the defined renewal cycle.
- Step 4** Enable NTP time setting, configure the **Renewal cycle**, and then click **Save**. The time of the Signage will be synchronized with that of the NTP server within the defined renewal cycle.

Figure 5-1 Date & time

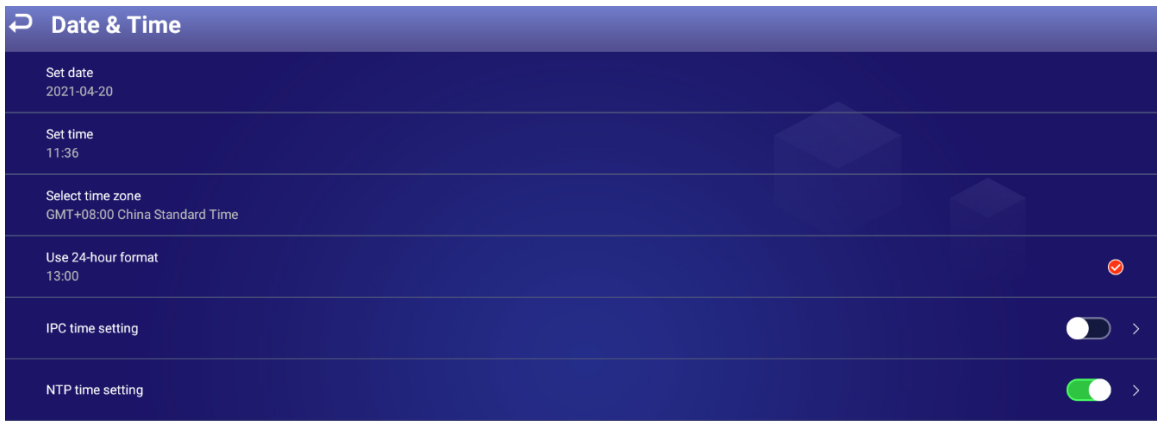

5.2 Selecting Input Source

Input sources include **Local** (default) and **HDMI**.

Background Information

Local : Play projects from your USB drive or through the platform.

HDMI : Play projects from the HDMI input source, for example, your PC.



Different devices support different input sources.

Procedure

- Step 1** On the main page, select **Settings** > **Input Source Setting**.

Figure 5-2 Input source

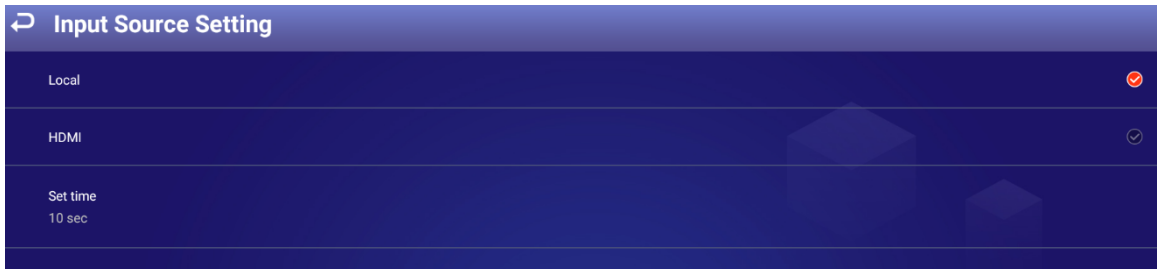

Step 2 Select input source.

- **Local** : Displays videos or pictures released locally or through the platform.
- **HDMI** : Displays images from HDMI input source.

Step 3 Configure HDMI waiting time.



If **HDMI** is selected, but there is no signal, the Signage displays **NO SIGNAL**. In this case, if the defined waiting time ends, the Signage will count down 10 seconds, and then display videos or pictures released locally.

5.3 Configuring Visual & Audio Parameters

Adjust display effect of screen and device volume.

Background Information



If it prompts **This operation may cause power increase. Do you want to continue?** , click **Confirm** to continue.

Procedure

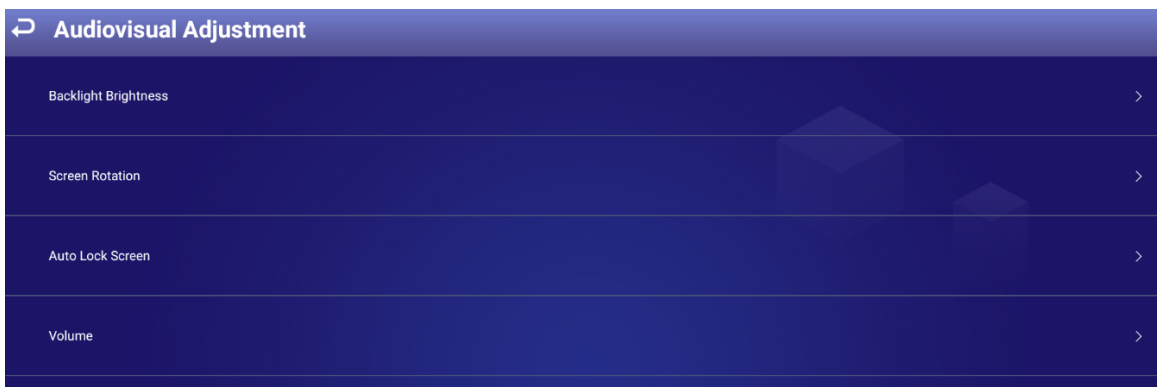

Step 1 On the main page, select **Settings** > **Audiovisual Adjustment**.

Figure 5-3 Audiovisual adjustment



Step 2 Configure visual & audio parameters.

Table 5-1 Visual & audio adjustment

Item	Description
Backlight Brightness	<p>Adjust the screen's background brightness manually or automatically.</p>  <p>Auto background brightness adjustment is available on select models.</p> <ul style="list-style-type: none"> • Auto: Enable Auto, and the background brightness will be adjusted according to the surrounding lighting conditions. • Manual: Disable Auto, and then you need to drag the brightness bar to adjust the background brightness manually. • Click  to restore to default value.
Screen Rotation	Rotate your screen with angles available on the Signage.
Auto Lock Screen	When your device is not playing any projects, you can set a device idle time (the time when you do not operate the device), beyond which your device will be locked.
Volume	<p>Adjust the volume of playing projects.</p> <ul style="list-style-type: none"> • Click Volume, and then drag the volume bar to adjust the volume. 0 represents muted. • Click  to restore to default value.

5.4 System Language

Select the display language from **Settings > Language**. Currently, only Chinese and English are available.

Figure 5-4 Language

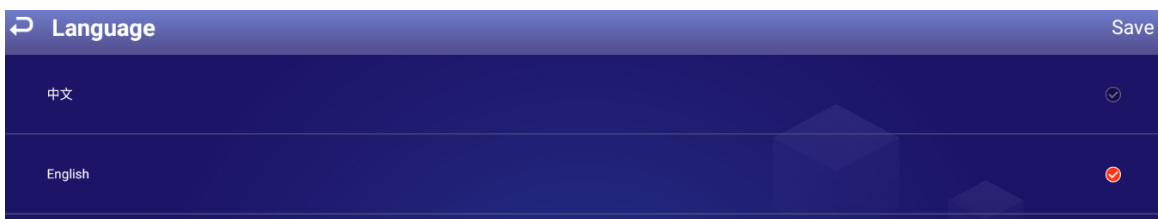

6 Maintenance and Update

6.1 Maintenance Requirements

To keep the Signage running normally, you need to:

- Change the user password every three months.
- Restart the Signage regularly.
- Update firmware regularly.

6.2 Restoring Factory Defaults

Restore your device to factory settings to handle problems such as storage insufficiency and system error. Be cautious because this might cause data loss.

Procedure

Step 1 On the main page, select **Settings** > **Maintenance and Upgrade** > **Restore Factory Defaults**.

Step 2 Click **Confirm**.

After restoring factory defaults, the Signage will restart.

Figure 6-1 Restoring factory defaults

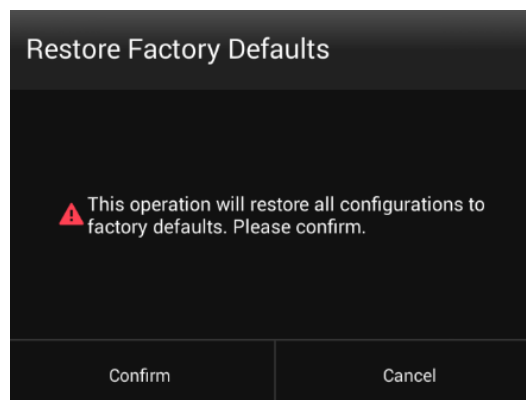

6.3 Upgrading System

Prerequisites

Insert a USB drive with the update package into your Signage. Contact our customer service to get an update package.



Downgrade from a higher version to a lower version is not supported.

Procedure

Step 1 On the main page, select **Settings** > **Maintenance and Upgrade** > **System Upgrade**.

Step 2 Select an update package to start update.

After being updated, your device restarts.

6.4 Configuring Auto Maintenance Time

By default, the Signage auto restarts at 1:00 a.m. each day. You can also set the time that the system auto restarts, and click **Save**. The system auto restarts at the specified time.

Procedure

- Step 1 On the main page, select **Settings > Maintenance and Upgrade > Auto Maintenance Time Setting**.
- Step 2 Drag your mouse up and down to select a time.
- Step 3 Configure the time. You can select the auto maintenance time on different time. For example, if you select 01:00 on **Sun** and **Fri**, the device will automatically reboot the system at 01:00 every Sunday and Friday.

Figure 6-2 Configure auto maintenance time

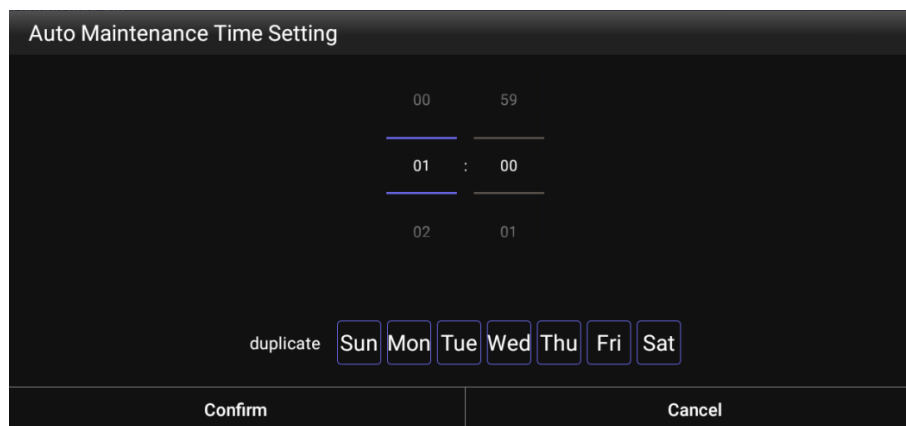

- Step 4 Click **Confirm**.

6.5 Configuring Timed Screen On/off

Procedure

- Step 1 On the main page, select **Settings > Maintenance and Upgrade > Timed Screen On/Off**.
- Step 2 Enable **By Week**, **Custom (Current day)** or **Custom (Cross day)** as needed.
- Step 3 Click **+** to configure the time.

Figure 6-3 Timed screen on/off



When **Custom (Current day)**, **Custom (Cross day)** and **Week** are enabled at the same time, the priority is Custom (Cross day) > Custom (Current day) > Week.

Step 4 Click **Save**.

6.6 Configuring Timed Power On/off

Procedure

- Step 1 On the main page, select **Settings** > **Maintenance and Upgrade** > **Timed Power On/Off**.
- Step 2 Enable **By Week**, **Custom (Current day)** or **Custom (Cross day)** as needed.

Figure 6-4 Timed power on/off

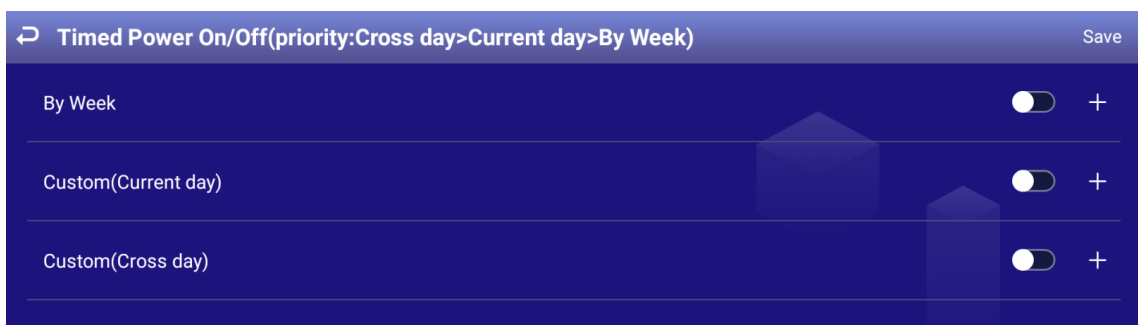

Step 3 Click **+** to configure the time.



When **Custom (Current day)**, **Custom (Cross day)** and **Week** are enabled at the same time, the priority is Custom (Cross day) > Custom (Current day) > Week.

6.7 Enabling HDMI Standby

On the main page, select **Settings** > **Maintenance and Upgrade** > **HDMI Standby**. Click  to enable this function. After you enable this function, HDMI will automatically turned off when there is no signal. For details about HDMI standby time, see "5.2 Selecting Input Source".

Figure 6-5 HDMI standby



6.8 Restarting Device

Manually restart your device to solve problems such as system crash.

Procedure

Step 1 On the main page, select **Settings** > **Maintenance and Upgrade** > **Restart Now**.

Step 2 Click **Confirm**.

The Signage starts restarting.

Figure 6-6 Restart now

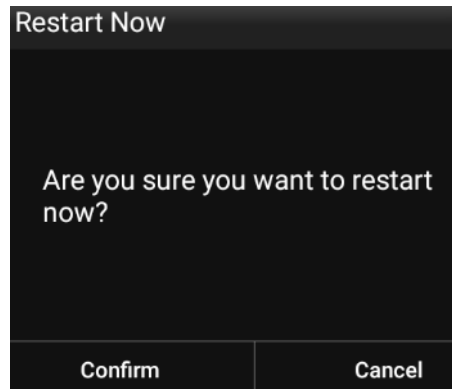

6.9 Viewing Device Information

On the main page, select **Settings** > **Terminal Info**, and then you can view device information such as device name, S/N, and app version.

Appendix 1 Remote Control

For Signage of specified models, you can use remote controls to operate them.













- The remote control supports limited operations: You can use the remote control to turn on or off the screen, turn on, turn off, or restart the Signage, adjust the volume and go back to the home page.
- Refer to the packing list to see whether the remote control comes with the Signage. If not, you need to purchase it separately.

Appendix Figure 1-1 Remote control appearance



Appendix Table 1-1 Buttons description

Operation Item	Buttons Needed
Power on/off device	Press  . In the pop-up dialog box, select Power off . Press the button again to power on the device.
Screen on/off device	Press  . In the pop-up dialog box, select Screen off . Press the button again to turn on the device screen.
Reboot	Press  . In the pop-up dialog box, select Reboot .
Adjust volume	<ul style="list-style-type: none"> • Volume up: Press  and press right arrow button. • Volume down: Press  and press left arrow button.

Operation Item	Buttons Needed
Log in	<ol style="list-style-type: none"> 1. When you find the screen is locked, you can use your remote control to type the password. Press  on your remote control. The Login page is displayed. 2. Operate arrow keys, move pointer to password box, and then type the password. 3. Move pointer to Done on virtual keyboard. 4. Move pointer to OK, and then press  on your remote control to log in to the device.
Return to the previous page	Press  .
Return to the main menu	Press  .
Bring up the frequently used tool bar	Press  , and operate the left/right arrow keys to select a function you want.

Appendix 2 Security Recommendation

Account Management

1. Use complex passwords

Please refer to the following suggestions to set passwords:

- The length should not be less than 8 characters;
- Include at least two types of characters: upper and lower case letters, numbers and symbols;
- Do not contain the account name or the account name in reverse order;
- Do not use continuous characters, such as 123, abc, etc.;
- Do not use repeating characters, such as 111, aaa, etc.

2. Change passwords periodically

It is recommended to periodically change the device password to reduce the risk of being guessed or cracked.

3. Allocate accounts and permissions appropriately

Appropriately add users based on service and management requirements and assign minimum permission sets to users.

4. Enable account lockout function

The account lockout function is enabled by default. You are advised to keep it enabled to protect account security. After multiple failed password attempts, the corresponding account and source IP address will be locked.

5. Set and update password reset information in a timely manner

The device supports password reset function. To reduce the risk of this function being used by threat actors, if there is any change in the information, please modify it in time. When setting security questions, it is recommended not to use easily guessed answers.

Service Configuration

1. Enable HTTPS

It is recommended that you enable HTTPS to access web services through secure channels.

2. Encrypted transmission of audio and video

If your audio and video data contents are very important or sensitive, it is recommended to use encrypted transmission function in order to reduce the risk of your audio and video data being eavesdropped during transmission.

3. Turn off non-essential services and use safe mode

If not needed, it is recommended to turn off some services such as SSH, SNMP, SMTP, UPnP, AP hotspot etc., to reduce the attack surfaces.

If necessary, it is highly recommended to choose safe modes, including but not limited to the following services:

- SNMP: Choose SNMP v3, and set up strong encryption and authentication passwords.
- SMTP: Choose TLS to access mailbox server.
- FTP: Choose SFTP, and set up complex passwords.
- AP hotspot: Choose WPA2-PSK encryption mode, and set up complex passwords.

4. Change HTTP and other default service ports

It is recommended that you change the default port of HTTP and other services to any port between 1024 and 65535 to reduce the risk of being guessed by threat actors.

Network Configuration

1. **Enable Allow list**

It is recommended that you turn on the allow list function, and only allow IP in the allow list to access the device. Therefore, please be sure to add your computer IP address and supporting device IP address to the allow list.

2. **MAC address binding**

It is recommended that you bind the IP address of the gateway to the MAC address on the device to reduce the risk of ARP spoofing.

3. **Build a secure network environment**

In order to better ensure the security of devices and reduce potential cyber risks, the following are recommended:

- Disable the port mapping function of the router to avoid direct access to the intranet devices from external network;
- According to the actual network needs, partition the network: if there is no communication demand between the two subnets, it is recommended to use VLAN, gateway and other methods to partition the network to achieve network isolation;
- Establish 802.1x access authentication system to reduce the risk of illegal terminal access to the private network.

Security Auditing

1. **Check online users**

It is recommended to check online users regularly to identify illegal users.

2. **Check device log**

By viewing logs, you can learn about the IP addresses that attempt to log in to the device and key operations of the logged users.

3. **Configure network log**

Due to the limited storage capacity of devices, the stored log is limited. If you need to save the log for a long time, it is recommended to enable the network log function to ensure that the critical logs are synchronized to the network log server for tracing.

Software Security

1. **Update firmware in time**

According to the industry standard operating specifications, the firmware of devices needs to be updated to the latest version in time in order to ensure that the device has the latest functions and security. If the device is connected to the public network, it is recommended to enable the online upgrade automatic detection function, so as to obtain the firmware update information released by the manufacturer in a timely manner.

2. **Update client software in time**

It is recommended to download and use the latest client software.

Physical Protection

It is recommended that you carry out physical protection for devices (especially storage devices), such as placing the device in a dedicated machine room and cabinet, and having access control

and key management in place to prevent unauthorized personnel from damaging hardware and other peripheral equipment (e.g. USB flash disk, serial port).